



new product

MGRA Series

Reduced Size
Thermoplastic, 6 and 12V



FEATURES

- Designed with aesthetics, ease of installation and performance in mind
- Compact, simple and contemporary
- Wall, optional ceiling or pendant mount (optional)
- Two-piece housing of injection-molded thermoplastic
- Two LED lamps, shielded by clear polycarbonate covers
- Sealed, maintenance-free, Lead-Calcium batteries
- Dual voltage input: 120/347 Vac.
- Up to 48W of total battery capacity
- Autotest (optional)
- Nexus interface (optional)
- Meets or exceeds CSA 22.2 No.141-15

See warranty details at: www.tnb.ca/en/brands/lumacell

TYPICAL SPECIFICATIONS

Supply and install the Lumacell® MGRA series of reduced size thermoplastic battery unit equipment. The unit construction shall include a housing and a front cover of injection-molded, high-impact thermoplastic of white color. No screws shall be necessary to hold the front cover to the housing. The unit shall be equipped at the bottom with two emergency heads with adjustable swivels and long-life LED lamps of ___V ___W protected by snap-on shock-absorbent, clear polycarbonate covers. The unit shall be suitable for wall mount or as otherwise specified.

The unit equipment shall have a dual-voltage input of 120/347Vac and shall be equipped with a test switch and a green pilot light, located on the front panel. The housing shall host the battery and the battery charger. The battery charger and other unit functions shall be driven by a micro-controller. All electronic circuitry shall be installed on a single printed circuit board. When specified, the unit equipped with Auto-test shall automatically self-test for one minute every 30 days, 10 minutes in the 6th month and 30 minutes annually. When a fault is detected, the bi-color pilot light shall turn from green to red and start flashing. A legend on a label installed near the pilot light shall explain the source of failure: battery, charger circuitry or lamp load.

The unit equipment shall be listed to the standard CSA 22.2 No.141-15.

The unit equipment shall be Lumacell® model: _____.

WIRE GUARDS

460.0080-L	Wall mount or ceiling mount
------------	-----------------------------

REPLACEMENT LAMPS

ORDERING CODE	TYPE	VOLTAGE/ WATTAGE
580.0097-L	MR16 LED	6V-4W
580.0122-L	MR16 LED	6V-5W
580.0093-L	MR16 LED	12V-4W
580.0104-L	MR16 LED	12V-5W
580.0106-L	MR16 LED	12V-6W

IN THE SAME THERMOPLASTIC FAMILY:



- Grande™ Series Exit Sign



- Grande™ Series Combo. Unit



new product

MGRA Series

Reduced Size Thermoplastic, 6 and 12V



DIMENSIONS

Dimensions are approximate and subject to change.

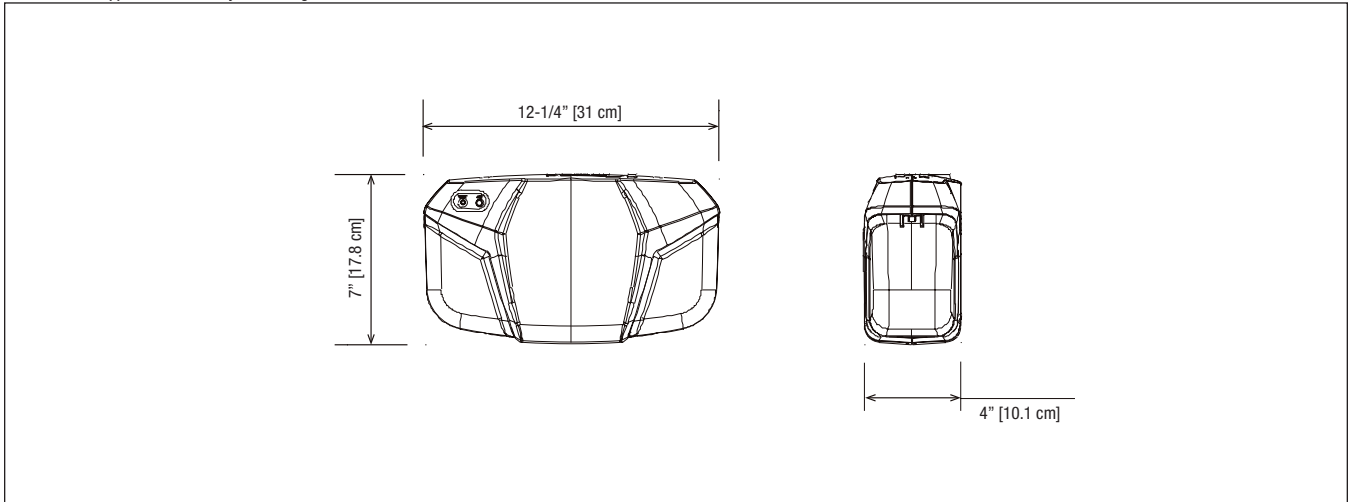

WALL MOUNT



POWER CONSUMPTION

MODEL	AC SPECS	WATTAGE CAPACITY					
		30MINS	1H	1,5H	2H	4H	
MGRA	120/ 347VAC	.11 /.04A	24W	14W	10W	8W	4W
MGR12A		.21 /.07A	48W	28W	20W	16W	8W

ORDERING INFORMATION

SERIES	CAPACITY	HEADS	LAMPS TYPE AND WATTAGE	COLOUR	VOLTAGE	UNIT TYPE	OPTIONS
MGRA = 6V	24= 24W	0= no head 2= two heads	LD1= MR16 LED, 6V-4W LD2= MR16 LED, 6V-5W LD7= MR16 LED, 12V-4W LD9= MR16 LED, 12V-5W LD10= MR16 LED, 12V-6W	W= factory white B= black	Blank= 120/347VAC ZC= 120/277VAC ZU= 120/208/220-240V 50/60Hz input ¹	AT= auto-test ¹ ATN= auto-test, non-audible ¹ Blank= standard NEXRF= wireless NEXUS [®] system interface ²	Blank= no options CM= ceiling mount LC= line cord (120V) PM= pendant mount ¹ T3= time delay (15 minutes)
MGR12A = 12V	48= 48W						

¹Minimum lamp load required:
20% of unit capacity.

²Not all options available with the Nexus[®] system.
Please consult your sales representative.

¹Pendant kit (sold
separately, see p.142)

EXAMPLE: MGRA242LD1W