



LMCS Series All Metal Exit Sign



FEATURES

- Pre-assembled for ease of installation
- Metal housing with baked enamel finish – will not yellow
- Easy access to wiring entry
- Long-life LED light source of **ALINGAP** technology assures low maintenance cost and is warrantied for ten (10) years
- Energy efficient, consumes less than 3W in stand-by mode
- Power pack comes standard with premium Lead-Calcium battery
- Other colours and options are available upon request
- Meets or exceeds CSA 22.2 No. 141-15

See warranty details at: www.tnb.ca/en/brands/lumacell

TYPICAL SPECIFICATIONS

Supply and install the **Lumacell® LMCS LED “SORTIE”** Exit Sign with power pack series. The exit housing and the faceplate(s) shall be constructed of steel. The Exit Sign shall have a maximum depth of 2-1/2” . The faceplate(s) shall come standard with knockout chevrons.

The light source shall be light emitting diodes (LED). Red LED technology shall be **ALINGAP**. The LED lamps shall provide illumination in normal and emergency operation and shall be mounted inside the exit housing, not on the face. An LED-sensitive diffuser shall be mounted behind the legend to provide the 6” (15cm) high by 3/4” (1.9cm) stroke letters with even illumination.

The power pack shall be a completely self-contained emergency unit with its own charger and rechargeable battery. The housing shall be made of steel. The unit shall be designed to furnish exit illumination from the normal AC source. When a power failure occurs, the mounted heads along with the Exit Sign are illuminated in emergency mode for a minimum of 30 minutes. The power pack shall be furnished with a test switch and high charge pilot light.

The heads shall require no tools to adjust and aim. The heads will be constructed of durable thermoplastic and use 6V, 4W lamps or as otherwise specified.

The Exit Sign shall be CSA 22.2 No. 141-15 certified.

The equipment shall be **Lumacell®** Model: _____ .

WIRE GUARDS

460.0078-L	Wall Mount
460.0060-L	Ceiling Mount

LMCS Series

All Metal Sign



DIMENSIONS

Dimensions are approximate and subject to change.

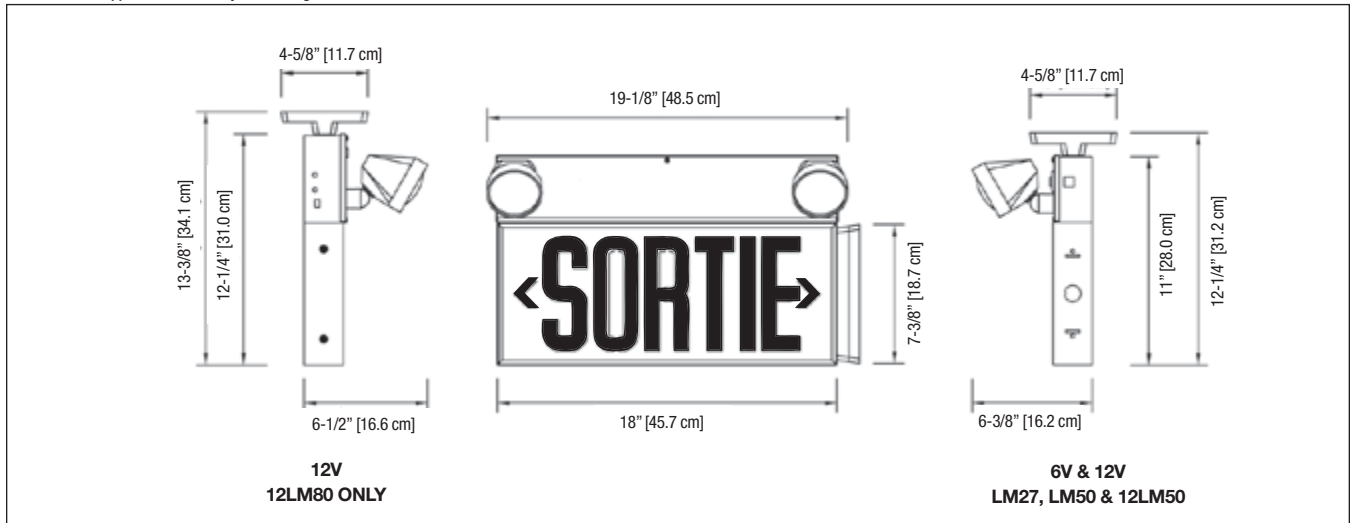

POWER CONSUMPTION AND UNIT RATING

MODEL	AC SPECS	WATTAGE CAPACITY					
		30MIN	1H00	1H30	2H00	4H00	
Sortie Sign Module	120/347VAC	Less than 2W	-	-	-	-	-
LM27		0.25/0.08A	27	15	12	9	-
LM50		0.25/0.08A	50	30	20	16	8
12LM50		0.25/0.08A	50	30	20	16	8
12LM80		0.25/0.08A	80	45	36	27	12

ORDERING INFORMATION

SERIES	MOUNTING/FACES	NUMBER OF HEADS	HEADS STYLE / WATTAGE	HOUSING COLOUR	VOLTAGE	OPTIONS
LM27 = 6V-27W LM50 = 6V-50W 12LM50 = 12V-50W 12LM80 = 12V-80W	CS1 = single face, wall or ceiling mount CSU = universal steel mount canopy with two faceplates	Blank = no heads 1 = one head 2 = two heads	Blank = no heads LD1 = MR16 LED, 6V-4W LD2 = MR16 LED, 6V-5W LD7 = MR16 LED, 12V-4W LD9 = MR16 LED, 12V-5W LD10 = MR16 LED, 12V-6W	Blank = factory white B = black TA = textured aluminium*	Blank = 120/347VAC	Blank = no options TP = tamper-proof screws T3 = time delay (15 minutes)
				* Black heads		*990.0119-L= tamper-proof bit (sold separately)

EXAMPLE: LM27CS12LD1