

Grounding Electrodes and Accessories

Galvanized Ground Rods

- Made of high strength quality cold drawn steel, (1035) hot dip galvanized
- Meet ANSI C135.30-1979 requirements
- Stainless steel rods are also available (for more detailed information, contact your T&B regional sales office)



Grounding

Cat. No.	Trade Size		Rod Size (nominal diameter x length)		Plating Thickness	Standard Packaging	Weight per 100	
	in.	ft.	mm	m			lb.	kg
GR5006	1/2	6	12.7	1.8	4 mils	10	410	186
GR6256	5/8	6	15.8	1.8	4 mils	5	600	272
GR6258	5/8	8	15.8	2.4	4 mils	5	800	363
GR6250 (0.543 – 0.555)	5/8	10	15.8	3.0	4 mils	5	1000	454
GR6260 (0.625 – 0.640)	5/8	10	15.8	3.0	4 mils	5	1000	454
GR6250B* (0.543 – 0.555)	5/8	10	15.8	3.0	4 mils	5	1000	454
GR7506	3/4	6	15.8	1.8	4 mils	5	700	318
GR7508	3/4	8	19.0	2.4	4 mils	5	1200	545
GR7510	3/4	10	19.0	3.0	4 mils	5	1500	681

* B suffix denotes black iron bare steel ground rod (CSA not applicable). CSA lists rods 1/2 in. and larger, 10 ft and longer.

Copper Bonded Steel Ground Rods

- All Blackburn® ground rods have a heavy uniform covering of electrolytic copper bonded to a rigid steel core
- Copper ions are forced electrically to join with the steel core, establishing a corrosion-resistant bond between the copper and the steel



Cat. No.	Trade Size		Rod Size (nominal diameter x length)		Plating Thickness	Standard Packaging	Weight per 100	
	in.	ft.	mm	m			lb.	kg
5005	1/2	5	12.7	1.8	5 mils	10	305	138
5006	1/2	6	15.8	1.8	5 mils	5	370	168
5008	1/2	8	15.8	2.4	5 mils	5	545	247
5010	1/2	10	15.8	3.0	5 mils	5	611	277
6256	5/8	6	15.8	3.0	5 mils	5	508	230
6258*	5/8	8	15.8	3.0	10 mils	5	678	308
6260*	5/8	10	15.8	1.8	10 mils	5	847	384
7508*	3/4	8	19.0	2.4	10 mils	5	992	450
7510*	3/4	10	19.0	3.0	10 mils	5	1240	462
1010*	1	10	25.4	3.0	10 mils	1	2248	1020

* Ground rods are UL listed (425H), except for regular rods shorter than 8 ft or less than 1/2 inch. CSA lists rods 1/2 in. and larger, 10 ft and longer.

Grounding Electrodes and Accessories

Sectional Copper Bonded Steel Ground Rods

- Sectional type ground rods have the same high quality as regular copper bonded steel ground rods, and are threaded top and bottom



Cat. No.	Trade Size		Rod Size (nominal diameter x length)		Plating Thickness	Thread Size	Standard Packaging	Weight per 100	
	in.	ft.	mm	m				lb.	kg
5006LS	1/2	6	12.7	1.8	10 mils	9/16-12	5	410	189
5008LS	5/8	6	15.8	1.8	10 mils	9/16-12	5	546	248
5010LS	5/8	8	15.8	2.4	10 mils	9/16-12	5	682	309
6256S	5/8	6	15.8	3.0	5 mils	5/8-11	5	481	230
6258S	5/8	8	15.8	3.0	10 mils	5/8-11	5	670	308
6260S	5/8	10	15.8	3.0	10 mils	5/8-11	5	837	384
7506S	3/4	6	15.8	1.8	5 mils	3/4-10	5	774	160
7508S	3/4	8	19.0	2.4	10 mils	3/4-10	5	992	450
7510S	3/4	10	19.0	3.0	10 mils	3/4-10	5	1040	562
1010S	1	10	25.4	3.0	10 mils	8-1	1	2248	1020

CSA lists rods 1/2* in. and larger, 10 ft and longer.

Couplings

- Threaded couplings are made of high strength, corrosion resistant alloy. Streamlined design reduces driving friction. Couplings are tapped for use on all standard threaded sectional rods



Cat. No.	Rod Size Diameter (in.)	Thread Size	Standard Packaging	Weight Per 100 (lb.)
50LC	1/2	9/16" - 12 UNS	25	17
60C	5/8	5/8" - 11 UNS	25	25
70C	3/4	3/4" - 10 UNS	25	38
80C	1	1" - 8 UNS	10	75

Driving Studs

- Driving Studs of high strength steel may be used with all standard threaded couplings



Cat. No.	Rod Size Diameter (in.)	Thread Size	Standard Packaging	Weight Per 100 (lb.)
50LDS*	1/2	9/16" - 12 UNS	10	16
60LDS*+	5/8	5/8" - 11 UNS	25	23
70LDS*	3/4	3/4" - 10 UNS	5	35
80LDS	1	1" - 8 UNS	10	75

* UL Listed.
+ CSA Listed.

Grounding Electrodes and Accessories

Threadless Couplings and Driving Caps for Standard Copper Bonded Ground Rods

Threadless Couplings

- For joining non-threaded, sectional, copper bonded, steel ground rods
- Coupling is manufactured of a high strength, corrosion resistant, silicone bronze

Threadless Driving Caps

- Prevent “mushrooming” of ground rod while driving to insure proper fit of coupling
- Driving cap is manufactured of high strength, hardened steel



G R O U N D I N G

Cat. No.	Size (in.)	Dimensions (in.)		Standard Packaging	Weight Per 100 (lb.)
		Length	Diameter		
Threadless couplings					
50CNT*	1/2	3.0	0.78	25	34
60CNT2*	5/8	2.5	0.69	25	34
70CNT*	3/4	3.0	0.97	25	31
Driving Caps					
60DSNT	5/8	4.0	0.88	10	43

* UL Listed.

Type DGC — Drive-On Ground Clamps

- Drive-on design provides easy tool free installation, high reliability compression fit connection, and room for one or two ground leads
- High-strength copper alloy provides increased tensile strength and long-term corrosion resistance for direct burial applications
- U.L. 486A and U.L. 467 Listed



Cat. No.	Ground Rod Size in. (mm)	Ground Wire Size
DGC58-44*	5/8 (0.555–0.565)	1 or 2-#4 sol.
DGC58-66*	5/8 (0.555–0.565)	1 or 2-#4 sol. 1-#4 sol.
DGC58-46	5/8 (0.555–0.565)	1-#6 sol.

* RUS Listed.

Grounding Electrodes and Accessories

Ground Rod Drivers

For installing ground rods, there's no safer, simpler or more effective tool than the Thomas & Betts Ground Rod Driver. It can be used on all types of ground rods including copper-bonded, galvanized and stainless steel.

Integral inserts prevent the driver from slipping off the rod near ground level. The inserts are 5/8" and 3/4", and are interchangeable with the standard driver body. The convenient retaining collar holds the insert in the tool when not in use.

Thomas & Betts Ground Rod Drivers have a heavy-duty steel construction that allows maximum force for driving ground rods, while the efficient design ensures that minimal lifting force is required. The ground rod end is designed for high impact applications to ensure quality connections.

- Unique design allows installation of 10-foot rods from ground level
- Heavy-duty steel construction
- Ergonomic grip provides ease and comfort with increased safety
- Complete with interchangeable parts that are range-taking for different diameter ground rods
- Two interchangeable inserts allow the same tool to be used with all sizes of rods
- Completely self-contained and easy to store



Photo includes ground rod driver and insert

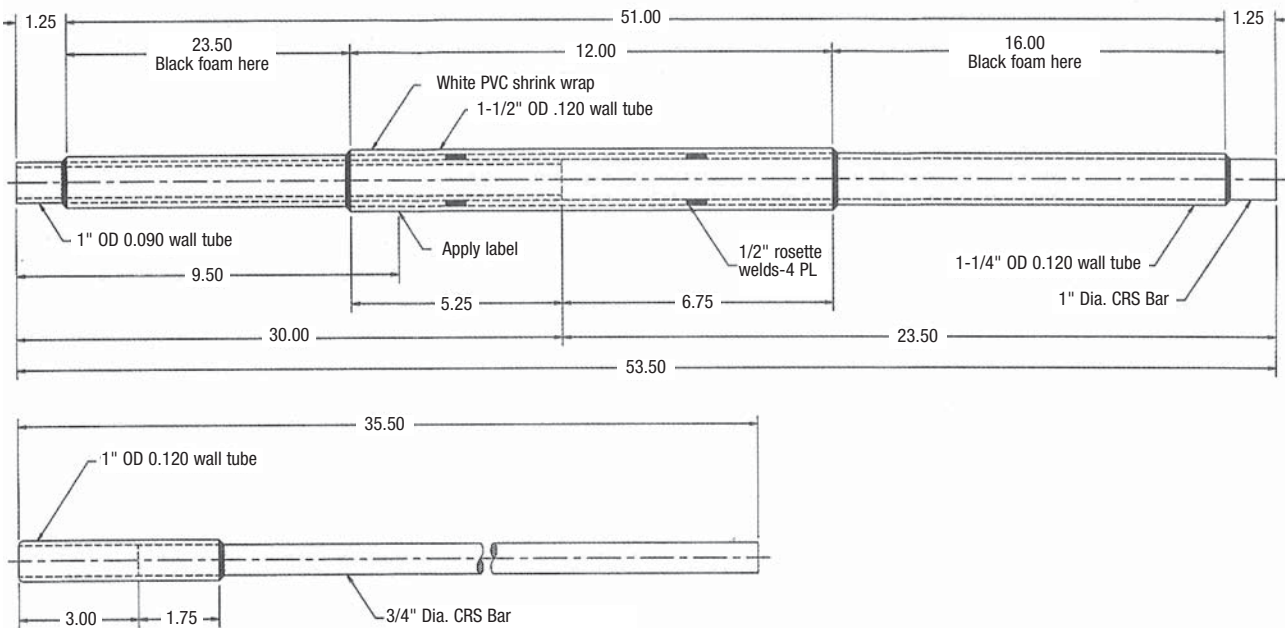

Cat. No.	Description	Weight (lb.)	Maximum Rod Diameter (in.)	Std. Pkg.
TBRD58	5 ft. Ground Rod Driver with 5/8" insert	25	0.63	1
TBRD34	5 ft. Ground Rod Driver with 3/4" insert	25	0.75	1
TBS58	Replacement 5/8" insert	4	0.63	1
TBS34	Replacement 3/4" insert	4	0.75	1

Grounding Electrodes and Accessories

Galvanized Grounding Plates

- Made of high quality steel, hot dip galvanized
- Major time and cost saving vs ground rods

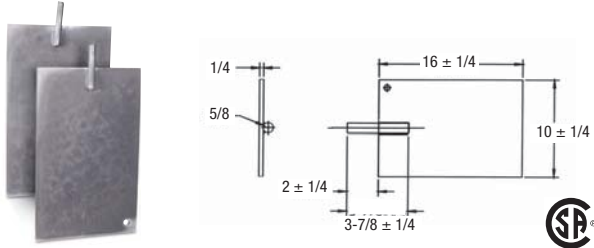

Cat. No.	Description	Wire Range	Std. Pkg.
1016TB	Galvanized grounding plate	—	1
1016BTB	Galvanized grounding plate complete with JAB34C connector	8 sol. to 4/0 str.	1
1016TB-NG*	Grounding plate (not galvanized)	8 sol. to 4/0 str.	1
1016BTB-NG*	Grounding plate (not galvanized) (complete with ground rod clamp)	8 sol. to 4/0 str.	1

* CSA not applicable.

Type GP — Copper Pole Bottom Ground Plates for Multigrounded Neutral Construction

- More efficient than butt wrapping poles
- Made of electrolytic sheet copper
- Built-in high pressure connector for ground lead, or supplied with #6 AWG copper pigtail pre-attached
- Plates are grooved for trapping moisture



Cat. No.	Pigtail Wire Range				Diameter of Plate	
	min.	max.	min. (mm²)	max. (mm²)	(in.)	(mm)
GP100	8	2 sol.	6.3	25.6	7-1/2	191
GP110					10	254
GP114					14	356
GP1003	#6 AWG solid CU Pigtail with 18" conductor	—	—	—	7-1/2	191
GP1008	#6 AWG solid CU Pigtail with 18" conductor	—	—	—	7-1/2	191
GP1108	#6 AWG solid CU Pigtail with 18" conductor	—	—	—	7-1/2	254

Ground Electrode Boxes

Cat. No.	Description
51628	Pregalvanized Steel
51629	Hot dip galvanized

14 gauge steel 10 inch diameter, 12 inch depth.



Metallic Gradient Control Mats

- To reduce risk and prevent build up of dangerous potential differences between high voltage equipment or structures and the user standing on the ground surface. CEC Rule 36-308



Cat. No.	Description	Std. Pkg.	WT/100	
			lb.	kg
64663	Mat with connectors	1	3000	1363

4 ft x 6 ft hot dip galvanized mat is made from 6" x 6" welded mesh. 1/4" diameter. Silicone bronze connector, bolt, nut and lockwasher

Type PB — Copper Pole Ground Plates

- Installed on butt end of utility poles to provide an economical, low resistance neutral ground
- Installed cost considerably less than butt-wrapped poles. Plate portion fabricated of .025" pure copper
- PBGW connector is eye-bolt type, cast of corrosion resistant aluminum bronze alloy, with silicon bronze nut and lock washer. Riveted all copper terminal lug is an integral part of the PBH, and provides the means of connection to the grounding conductor



Cat. No.	Wire Range		Finished Size (in.)	Surface Area sq. in.
	max.	min.		
PBGW	2/0 str.	10 sol.	7 x 7-5/8	56
PBH*	4 str.	14 sol.	7 x 7-3/8	56

* RUS Listed.

Grounding