

T&B Conduit Fittings

Rigid and Intermediate Metal Conduit Fittings

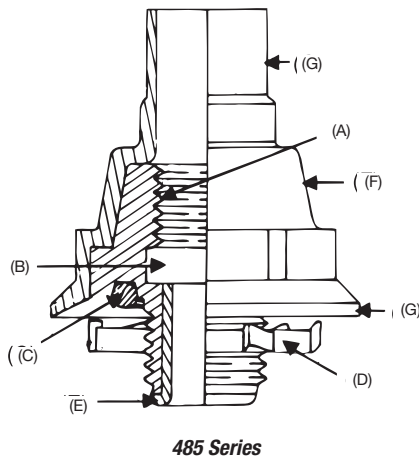
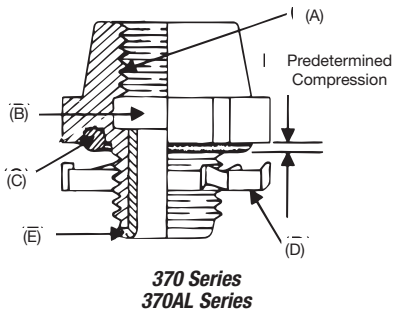

Threaded Hubs (Bullet® Hubs)

(For Threaded Rigid Metal Conduit/IMC/PVC Coated Rigid Metal Conduit)

Application

- To connect threaded metal conduit (ferrous rigid/nonferrous rigid/PVC coated/or intermediate metal) to a threadless opening in a box or enclosure in outdoor or indoor location exposed to continuous or intermittent moisture.

- To positively bond conduit to box or enclosure.

Features

- Rugged steel/malleable iron/copper-free aluminum construction.
- Tapered internal threads for watertight/dust tight union (A).
- Threads relieved to prevent bottoming of conduit ensuring sound assembly (B).
- Recessed sealing ring at box end. Captive sealing ring (C).
- Hardened steel/malleable iron/copper-free aluminum locknuts designed to provide high quality ground continuity; extended reach of locknut permits clamping on thin boxes and enclosures (D).
- Insulated throat protects conductors, prevents abrasion and thinning of conductor insulation, reduces wire pull effort (E).

- Suitable for hazardous location use per following:

- (i) Class II, Division 1 Groups E, F, G, CEC Rule 18-202
- Class II, Division 2 Groups E, F, G, CEC Rule 18-252
- Class III, Division 1 Rule 18-302
- Class III, Division 2 Rule 18-352

- PVC coated 485 Series

- (i) Protects fitting from extremely corrosive surroundings without affecting integrity of electrical grounding path (F).
- (ii) Provided with overlapping sleeve for additional seal (G).

Canadian Electric Code Rule 10-602 states that, "Where dissimilar metals cannot be avoided at bonding connections as indicated in Rule 2-112 (2). Connections shall be made using methods or material that will minimize deterioration from galvanic action".

Joint Industrial Council (JIC) Electrical Standards also forbid dissimilar metals in contact for the same reason and require that the fittings for metal conduit be of malleable iron or ductile iron and have impact strength comparable to that of the conduit.

"Copper-free Aluminum"

- Copper-free aluminum castings for fittings have a maximum of 0.4% copper. The most detrimental effect of higher percentage of copper on aluminum base alloy is its decrease in corrosion resistance.

T&B Conduit Fittings

Rigid and Intermediate Metal Conduit Fittings

Threaded Hubs (Bullet® Hubs)—continued

(For Threaded Rigid Metal Conduit/IMC/PVC Coated Rigid Metal Conduit)

Standard Material

	370-485 Series	370AL
Body	1/2" thru 1" Steel 1-1/4" thru 6" Malleable Iron	All Copper-Free Aluminum
Locknut	1/2" thru 2" Steel (hardened) 2-1/2" thru 6" Malleable Iron	1/2" thru 2" Steel (hardened) 2-1/2" thru 4" Copper-free Aluminum
Screws	Steel (hardened)	
'O' Ring	Buna N	
Insulator	Nylon	
Coating	PVC	

Standard Finish

	370 Series	370AL Series	485 Series
Hub	Electro-zinc Plated	As Cast Chromate Coated.	PVC—Outside. Electro-zinc Plated Chromate Coated Inside.
Locknuts	All Ferrous locknuts Electro-Zinc Plated and Chromate Coated.		
Screws	All Electro-Zinc Plated & Chromate Coated.		

Range

370 Series 1/2" thru 6" Conduit
 370AL & 485 Series 1/2" thru 4" Conduit
 All hub threads—straight pipe
 All female threads—taper pipe
 (NPT)

Conformity

U.L. 514B
 CSA 22.2 No. 18.3
 ANSI C80.4
 NFPA 70-2008 (ANSI)
 NEMA FB-1
 JIC EGP1; JIC EMP 1
 Federal Specification W-F-408
 Federal Standard H-28 (Threads)

T&B Conduit Fittings

Rigid and Intermediate Metal Conduit Fittings

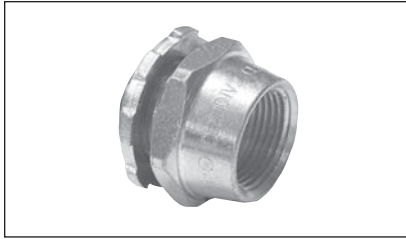

Nylon insulated.

Aluminum, steel, or malleable iron (steel through 1"). With Neoprene "O" Ring provides a watertight threaded hub on enclosures. U.L. Listed 105°C.

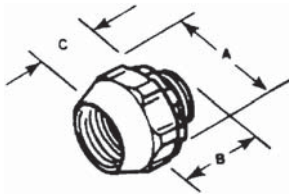

Steel/Malleable Iron and Aluminum Hub Fittings[†]

Stl. or M.I.	Cat. No.	Alum.**	Size	Dimensions (in.)			Wall Thk. (max.)in.
				A	B	C	
370	370AL		1/2	1-3/8	1-5/16	3/4	5/16
371	371AL		3/4	1-5/8	1-3/8	7/8	5/16
372	372AL		1	2-3/32	1-23/32	1-7/32	5/16
373	373AL		1-1/4	2-9/16	2	1-11/32	5/16
374	374AL		1-1/2	3-3/32	2	1-11/32	5/16
375	375AL		2	3-5/8	1-31/32	1-11/32	5/16
376	—		2-1/2	4-1/8	2-21/32	1-15/16	5/16
377	—		3	5	2-31/32	2	1/2
378	—		3-1/2	5-9/16	3-1/8	2-1/8	1/2
379-TB	—		4	6-9/16	3-1/8	2-1/8	1/2
381-TB	—		5	8	4	2-3/16	1/2
382-TB	—		6	9-3/16	4	2-3/16	1/2

** Aluminum not available with insulated throat.

[†] U.L. Listed raintight and CSA Certified watertight and dust tight.

For Dura-Plate™ finish, add prefix 040- to Cat. No. Consult Customer Service for details.

Bullet® Hub Fittings with Bonding Locknut — Nylon Insulated



Cat. No.	Size (in.)	Description
401	1/2	
402	3/4	
403-TB	1	Available in steel or malleable iron
404-TB	1-1/4	(steel through 1 inch.)
405-TB	1-1/2	Used with a neoprene "O" ring to provide
407	2-1/2	Supplied with 106 series bonding nut.
408	3	Temperature rating: 105°C.
409	3-1/2	
410-TB	4	

CSA certified watertight and dust tight.

T&B Conduit Fittings

Rigid and Intermediate Metal Conduit Fittings



PVC Coated Hub for Rigid Conduit



Steel or malleable iron (steel thru 1-1/4").

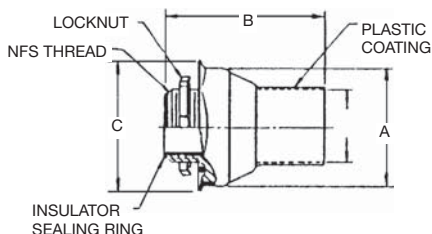

Cat. No.	Conduit Size	Dimensions (in.)		
		A	B	C
485	1/2"	1-21/64	2-1/8	1-7/8
486	3/4"	1-19/32	2-3/8	2-1/8
487	1"	1-27/32	2-3/4	2-3/8
488	1-1/4"	2-15/32	3-3/8	3-1/8
489	1-1/2"	2-29/32	3-5/8	3-1/2
490	2"	3-3/8	3-3/4	4
491	2-1/2"	3-27/32	4	4-1/2
492	3"	4-21/32	4-5/8	5-3/8
493	3-1/2"	5-9/64	4-13/16	5-7/8
494	4"	5-3/4	4-9/16	6-7/16

*485 Series are CSA Certified Watertight and Dustight for Ordinary Locations.

Spacing Chart for Bullet® Hubs



	Center to Center Spacing Conduit Sizes										Min. Space from Center of Bullet® Hub to Wall of Box	KO Diameters (min.)
	1/2	3/4	1	1-1/4	1-1/2	2	2-1/2	3	3-1/2	4		
1/2	1-7/16	1-5/8	1-3/4	2-1/8	2-3/8	2-5/8	2-7/8	3-5/16	3-1/2	3-7/8	3/4	7/8
3/4	—	1-3/4	1-7/8	2-1/4	2-1/2	2-3/4	3	3-1/2	3-3/4	4-1/8	7/8	1-1/8
1	—	—	2	2-3/8	2-5/8	2-7/8	3-1/8	3-5/8	3-7/8	4-1/4	1-1/8	1-3/8
1-1/4	—	—	—	2-11/16	2-15/16	3-1/4	3-1/2	4	4-1/4	4-1/2	1-3/8	1-3/4
1-1/2	—	—	—	—	3-1/8	3-1/2	3-3/4	4-1/8	4-3/8	4-3/4	1-5/8	2
2	—	—	—	—	—	3-3/4	4	4-1/2	4-3/4	5	1-7/8	2-1/2
2-1/2	—	—	—	—	—	—	4-1/4	4-3/4	5	5-3/8	2-1/8	3
3	—	—	—	—	—	—	—	5-1/8	5-3/8	5-3/4	2-5/8	3-5/8
3-1/2	—	—	—	—	—	—	—	—	5-5/8	6	2-7/8	4-1/8
4	—	—	—	—	—	—	—	—	—	6-1/4	3-1/4	4-5/8

T&B Hub Centerline Spacing Chart



Conduit Trade Size inc.	1/2"	3/4"	1"	1-1/4"	1-1/2"	2"	2-1/2"	3"	3-1/2"	4"	5"	6"
1/2"	1-9/16											
3/4"	1-43/64	1-25/32										
1"	1-27/32	1-61/64	2-1/8									
1-1/4"	2-1/32	2-9/64	2-5/16	2-1/2								
1-1/2"	2-7/32	2-21/64	2-1/2	2-11/16	2-7/8							
2"	2-15/32	2-37/64	2-3/4	2-15/16	3-1/8	3-3/8						
2-1/2"	2-23/32	2-53/64	3	3-3/16	3-3/8	3-5/8	3-7/8					
3"	3-1/32	3-9/64	3-5/16	3-1/2	3-11/16	3-15/16	4-3/16	4-1/2				
3-1/2"	3-11/32	3-21/64	3-5/8	3-13/16	4	4-1/4	4-1/2	4-13/16	5-1/8			
4"	3-19/32	3}	3-7/8	4-1/16	4-1/4	4-1/2	4-3/4	5-1/16	5-3/8	5-5/8		
5"	4-9/32	3-25/64	4-9/16	4-3/4	4-15/16	5-3/16	5-7/16	5-3/4	6-1/16	6-5/16	7	
6"	4-11/16	4-51/64	4-31/32	5-5/32	5-11/32	5-19/32	5-27/32	6-5/32	6-15/32	6-23/32	7-13/32	7-13/16

Nearest obstruction to center of hub.

	27/32	61/64	1-1/8	1-5/16	1-1/2	1-3/4	2	2-5/16	2-5/8	2-7/8	2-9/16	3-31/32
--	-------	-------	-------	--------	-------	-------	---	--------	-------	-------	--------	---------