

# T&B

## Cable Ties

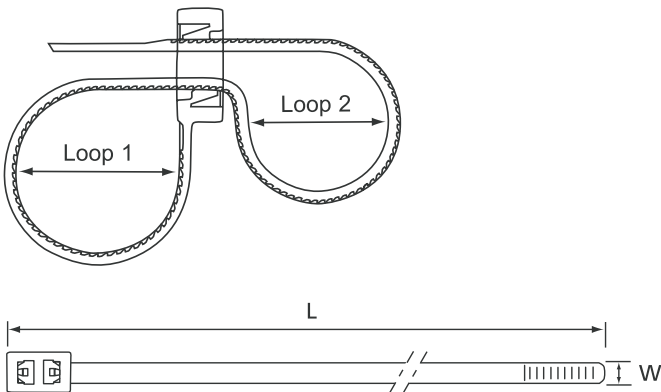

Double Loop ties allow the parallel routing of two bundles of cable with one single tie. Available in 3 different lengths.



# T&B

## Cable Ties

### One Tie, Two Loops

Double Loop Cable Ties allow the parallel routing of two bundles of cable with one single cable tie. The unique design loops itself twice through the head of the tie in separate latching pawls. Applications include appliance manufacturers, automotive, aerospace, data communications, and electrical equipment manufacturers.

### Advantages:

- Manufactured of natural color nylon 6/6 material
- Temperature range of -40°F to 185°F
- UL 94 V-2 flammability rating
- Halogen and silicone-free to meet your application needs
- The integrally formed pawl combines low insertion and high locking strength
- A rounded, low-profile head makes for less snags
- Tails have improved two-sided finger grip design that helps the operator grasp and pull ties snug
- Quick and easy pull through increases productivity, reduces operator fatigue



### Double Loop Cable Ties Information

Catalog Number	Length (in.)	Width (in.)	Bundle Diameter Range		Min. Tensile Strength	Installation Tooling For All Sizes	Package Quantity
			Loop 1 (in.)	Loop 2 (in.)			
TB-50RLDH	7.8	.19	.1 - 1.8	.1 - 1.7	50	ERG-50	1000
TB-12-50RLDH	11.8	.19	.1 - 2.8	.1 - 2.7	50	ERG-120	1000
TB-15-50RLDH	14.6	.19	.1 - 3.9	.1 - 3.8	50	WT193A, TR227	1000