

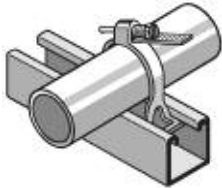

**ADJUSTABLE PIPE CLAMP**



Nominal Pipe Size		Cat. No.	Pipe O.D. Range		Design Load		Max. Torque	
in.	mm		in.	mm	lbs.	N	in.-lbs.	N-m
1/2 to 3/4	15-20	<b>NM-SAPC050</b>	75 to 1.05	19 to 28	75	.33	15	1.69
1 to 1-1/2	5-40	<b>NM-SAPC100</b>	1.05 to 1.90	29 to 48	150	.67	22	2.48
1-1/2 to 2-1/2	40-65	<b>NM-SAPC112</b>	1.90 to 2.87	48 to 73	150	.67	22	2.48
2-1/2 to 3-1/2	65-90	<b>NM-SAPC212</b>	2.87 to 4.0	73 to 101	150	.67	22	2.48

Safety Factor of 3 on Design Load.

**Not recommended for vertical installation without additional supports**

**RIGID PIPE CLAMP**

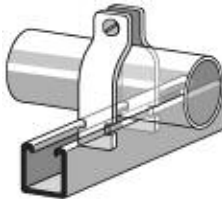

Nominal Pipe Size		Cat. No.	Design Load		Max. Torque	
in.	mm		lbs.	N	in.-lbs.	N-m
1/2	15	<b>NM-SRPC050</b>	300	1.33	10	1.13
3/4	20	<b>NM-SRPC075</b>	300	1.33	10	1.13
1	25	<b>NM-SRPC100</b>	300	1.33	10	1.13
1-1/4	32	<b>NM-SRPC114</b>	300	1.33	10	1.13
1-1/2	40	<b>NM-SRPC112</b>	300	1.33	10	1.13
2	50	<b>NM-SRPC200</b>	300	1.33	10	1.13
2-1/2	65	<b>NM-SRPC212</b>	300	1.33	10	1.13
3	80	<b>NM-SRPC300</b>	300	1.33	10	1.13
3-1/2	90	<b>NM-SRPC312</b>	300	1.33	10	1.13
4	100	<b>NM-SRPC400</b>	300	1.33	10	1.13

Safety Factor of 3 on Design Load.

**Not recommended for vertical installation without additional supports**

**CONDUIT SWIVEL CLAMP**

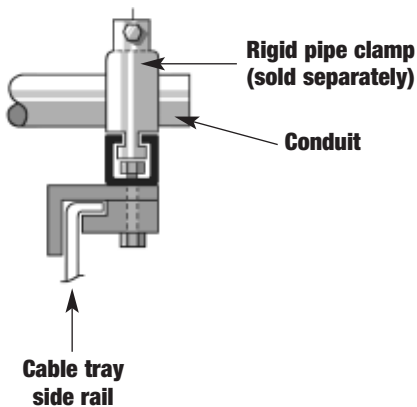

**Catalog No.**

**NM-SCSC-(CTD)**

Cable Tray Designation (CTD) required (Ex. 6CP Series designates 6" deep polyester resin).  
Pipe Clamps are a separate order item.