

—  
A

## Star Teck® - Teck and tray cable fittings



—  
A

# Star Teck - Teck and tray cable fittings

---

# Table of contents

## Section A

<b>The Star Teck family</b>	A4
<b>Specifications</b>	A6
<b>Hazardous locations – CEC classifications</b>	A8
<b>Hazardous locations – class, zone and division certifications</b>	A12
<b>Quick reference</b>	A13
<b>Star Teck (ST®) – series fittings for Teck and ACWU cable</b>	A14
<b>Star Teck XP® (STX®) – hazardous location series fittings for Teck cable</b>	A16
<b>Star Teck Extreme® (STE®) – series fittings for Teck cable and ACWU cable</b>	A18
<b>Star Teck Extreme XP® (STEX®) – hazardous location series fittings for Teck cable</b>	A21
<b>Star Teck ST90 series – 90-degree Teck fittings</b>	A25
<b>Bond Star® – grounding locknut</b>	A26
<b>10464 Series – watertight fittings/ ACWU</b>	A28
<b>90° Watertight fittings and non-watertight Teck cable fittings</b>	A29
<b>Tray Star™ HLT series – hazardous location fittings for tray cable</b>	A30
<b>Silver Grip® – TCF series tray-cord fittings</b>	A32
<b>Accessories</b>	A34

---

# The Star Teck family

## A tradition of industry firsts

A pioneer in the design and manufacture of Teck cable fittings, the Star Teck product line remains an indisputable industry standard to this day.

Since the introduction of the 10464 fitting in 1953, our engineers have gathered feedback from end-users working in the harshest and most corrosive industrial environments to bring you the Star Teck line of high performance Teck cable fittings which, year after year, remains the industry benchmark for safety, quality construction and ease of installation.

Designed and manufactured in Canada to meet the unique challenges of Canadian industry, the Star Teck cable fittings line continues to evolve, keeping pace with technological advances whilst improving performance and installation efficiency.

### 1988 – Star Teck (ST series) fittings

A natural extension of the 10464 series, the first Star Teck cable fitting incorporated input from end-users in Canadian industry and was the first Teck fitting to use a “pop-on” design requiring no disassembly. Other unique features included a splined gland and gripping features. The original Star Teck fitting for Teck and ACWU cable set the standard for ease of installation, quality engineering and safe, reliable terminations in challenging industrial environments.



### 1990 – Star Teck XP (STX series) fittings

Working with engineers from the Canadian petrochemical, oil and gas industries, T&B then introduced the Star Teck XP fitting. With an easy-to-fill, integral sealing chamber and a disconnectable design requiring minimal cable preparation, this fitting became the benchmark for ease of installation in hazardous environments. A line of liquid and putty sealants was also developed at the same time, eliminating the need for the cement sealants used up to this point.



---

## The Star Teck family

### 1997 – Star Teck Extreme (STE series) fittings

The Star Teck Extreme fitting was the industry's first range-taking Teck fitting. This fitting simplified matching cables to fittings and reduced the number of different size fittings that had to be inventoried. Now one Star Teck Extreme fitting could cover the range of three conventional Star Teck fitting hub sizes. With the Star Teck Extreme fitting also came the invention of removable armour stops, another feature that has since become an industry standard.



### 998 – Star Teck Extreme XP (STEX series) fittings

With the introduction of Star Teck Extreme XP fittings, T&B combined the ease of installation of the original Star Teck XP fitting with all of the unique benefits of Star Teck Extreme range-taking fittings. End-users in hazardous, explosion-proof environments could now benefit from simplified fitting selection, reduced inventory and removable armour stops.



### 2000 – Bond Star grounding locknut

Developed in response to the increased use of microprocessors, controllers, instrumentation and data communications in demanding industrial environments, the Bond Star grounding locknut was designed for use in data and control applications sensitive to floating voltage differences.



## Specifications

### Teck cable

Teck cable derived its name from one of its first users, the Teck-Hughes Gold Mines in Kirkland Lake, Ontario. Teck 90 is a CSA Type designation. Trade designation of this cable is armoured cable.

Teck cables up to 5,000 volts working potential are manufactured in accordance with CSA Standard C22.2 No. 131 and are provided with a bare ground conductor and an optional outer jacket. Depending on phase conductor insulation, the cables are designated as Teck 90 (X-LINK) when insulation is cross-linked polyethylene and Teck 90 (EP) when insulation is ethylene propylene. Both cables are rated for 90 °C service (dry location) and 75 °C (wet locations). Teck cable suitable for installation down to -40 °C is marked Teck 90 (X-LINK) minus 40 or Teck 90 (EP) minus 40.

Over 5,000 volts working potential Teck cables are manufactured in accordance with IPCEA standards and are certified by CSA. Cables are provided with or without ground wire as required.

Teck cables with outer jacket may be used for exposed or concealed wiring in wet or dry locations, indoors/outdoors and in corrosive environments. Teck cables are suitable for use in ventilated, non-ventilated and ladder type cable troughs, in ventilated flexible cable ways in both dry and wet locations. Teck cable with outer jacket is suitable for direct earth burial and for Class II Division 2, Class III, Divisions 1 and 2 hazardous locations per Canadian Electrical Code.

Some of the features of Teck cable are its flexibility and ease of installation. Absence of dead air space within the cable increases heat transfer and minimizes condensation. Overall protective covering provides good environmental protection.

Bend radius for permanent training during installation usually varies between 7 to 12 times the cable diameter depending on cable construction and manufacturer's recommendations. Larger radius bends are required for other conditions. Section 12-3028 of the Canadian Electrical Code requires that the terminating fittings used must provide adequate strain relief to terminal connections and ensure electrical continuity without injury to nonmetallic sheath. Continuity is mandatory whether or not the armour is used as a grounding conductor. Except for dry locations free from corrosive atmosphere, the nonmetallic jacket is not permitted to be stripped back to a point where armour is exposed after installation.

Where single conductor cables carrying 200 amps or more enter metal boxes through separate openings, certain precautions are required to prevent overheating of the metal by induction. Use of non-ferrous or nonmetallic box connectors, locknuts and bushings and installation of non-magnetic panel inserts is suggested in the code.

Please refer to the following for further details and complete information:

1. CEC Section 12...Wiring methods  
CEC section 4...Conductors
2. CSA C22.2 No. 131...Safety standard for type Teck cable
3. CSA C22.2 No. 18.1...Safety standards for outlet boxes
4. CSA C22.2 No. 18.3...Safety standards for conduit, tubing and cable fittings

Please note:

The excerpts and other material herein, whether relating to the National Electrical Code, the Underwriters Laboratories, Inc. listing, to industry practice or otherwise, are not intended to provide all relevant information required for use and installation. Reference to original or primary source material and data is mandatory before any application or use is made of the product.

CSA Certified

CSA Certified for use in hazardous locations of class I, II, III. Suitable for locations of Class I with a Class I certified anti-explosion firewall. cCSAus Certified for use in hazardous locations; i.e. e II, Class I, Zone I, AEx e II compliant with CCC and NEC.



## Specifications

### Metal-clad cable and aluminum-sheathed cable

“Metal clad cable type MC is a factory assembly of one or more conductors, each individually insulated and enclosed in a metallic sheath of interlocking tape, or a smooth or corrugated tube.”

Metal clad cable type MC is rated for use up to 5,000 volts. The National Electrical Code permits use of metallic sheath as an equipment grounding conductor.

Metal clad cables are available with a variety of phase conductor insulations such as cross-linked polyethylene, and silicone rubber ethylene propylene, depending on rated temperature of conductors and working potential. Metallic sheath can be of galvanized steel, aluminum, copper or bronze. A special outer covering such as PVC or neoprene over metallic sheath is usually provided for environmental protection.

Metal clad cable is not permitted in locations where it could be subject to physical damage. Metal clad cable can be used exposed, concealed, in cable tray, in any approved raceway, and, with minor exceptions, in hazardous locations. Type MC cable can also be used for services, feeders, branch circuits, power, lighting, control and signal circuits.

Use of metal clad cable is permitted in wet locations, or where exposed to destructive corrosive conditions or directly buried in earth, concrete or exposed to cinder fills, strong chlorides, caustic alkalis, vapors, chlorine or hydrochloric acids provided the construction of cable, the conductors within the metallic sheath, the metallic sheath and protective cover over metallic sheath comply with requirements enumerated in Sec. 334-3 of the National Electrical Code.

Bend radius restrictions are dependent on the size of the cable and the type of sheath, i.e. smooth, interlocked armour, corrugated sheath or shielded conductors, and varies from 7 to 15 times cable external diameter.

NEC Article 330 requires that approved fittings be used for termination. Where single-conductor cables carrying alternating current enter a ferrous metal box or enclosure, procedures described in NEC Section 300-20 must be followed to reduce effects of heating due to induced currents. These procedures include recommended arrangements of conductors, cutting of slots in metal between individual conductor holes, passing of conductors through insulating walls or use of non-magnetic aluminum sheathed cable and aluminum terminating fittings.

Portions of this section reprinted by permission from NFPA® 70 Electrical Code, copyright National Fire Protection Association, Boston, MA.

Please refer to the following for further details and complete information:

1. NEC Article 330...Metal clad cable (type MC)
2. UL 4, ANSI C33.9...Safety standards for type MC metal clad cable
3. ANSI C33.84...Safety standards for outlet boxes and fittings
4. W-F-406...Federal specification. Fittings for cable, power electrical and conduit metal, flexible
5. NEMA FM-1...Standards publication. Fittings and supports for conduit and cable assemblies
6. UL514A...Safety standards for metallic outlet boxes
7. UL514C...Safety standards for conduit, tubing and cable fittings



## Hazardous locations – CEC classifications

### Class I

#### CEC code changes

In 1998, the Canadian Electrical Code® (CEC) adopted the International Electrotechnical Commission's (IEC) "three zone area" classification system for Class I hazardous locations. The zone system is an alternate classification for Class I hazardous locations and was adopted to promote harmonization with international standards.

The division system for Class I hazardous locations continues to be used for existing facilities and is expected to remain in use at least for the next few editions of the CEC. For this reason, this catalogue's certification information for Class I hazardous locations includes both the pre-1998 division system and the new IEC zone system. The following pages provide an overview of CEC hazardous location classifications.

#### Classes

The Canadian Electrical Code (CEC), Part I, Section 18-Hazardous locations, identifies three classes of hazardous locations:

- Class I – gas and vapour environments
- Class II – dust environments
- Class III – fibers and flying environments

#### The 1998 revisions to the CEC affect only Class I – gas and vapour environments.

Hazardous location is defined by the CEC as premises, buildings or parts thereof in which there exists the hazard of fire or explosion due to highly flammable gases and/or flammable, volatile liquid mixtures that are manufactured, used or stored in other than the original containers.

This definition can also be extended to include combustible dust and easily ignitable fibers that are likely to be present in sufficient quantities to produce an explosive mixture.

#### Class I – gas and vapour environments

Locations which are deemed hazardous due to the presence of gases or vapours that are present in the air in sufficient quantity to produce explosive or ignitable mixtures.

Locations identified as Class I require that enclosures and fittings be explosion proof.

Class I hazardous locations are further subdivided into:

- Divisions (pre-1998 version of the CEC), or
- Zones (IEC Classification - 1998 CEC)

The division system may still be used for the maintenance and repair of existing facilities. All new construction must use the IEC zone classification.

#### Divisions

- Division 1 – a Class I location where the hazardous atmosphere is expected to be present during normal operations on a continuous, intermittent or periodic basis.
- Division 2 – a Class I location in which volatile flammable liquids or gases are handled, processed or used but in which they would normally be confined within closed containers or closed systems from which they can escape only in the event of an accidental rupture or breakdown of the containers or systems.

The following abbreviations are used in this catalogue:

HLA – hazardous location area

OLA – ordinary location area



#### Area classification – Divisions vs. zones

Continuous hazard	Intermittent hazard	Hazard under abnormal conditions
Zone 0	Zone 1	Zone 2
Division 1	Division 1	Division 2



## Hazardous locations – CEC classifications

### Class I

—  
01 This diagram illustrates the escape paths of gases generated by an explosion within an electrical enclosure. When an explosion occurs, hot or burning gases pass through the threaded joint or Star Teck XP flame path and must make a number of changes in direction. These changes in direction cool the hot gases to the point that they are too cool to ignite the surrounding atmosphere once they escape.

Other escape paths for the hot gases include the enclosure cover flange and the interstices between the strands of wires entering the enclosure.

#### Zones

- Zone 0 – Class I locations in which explosive gas atmospheres are present continuously or are present for long periods.
- Zone 1 – Class I locations in which:
  - i. explosive gas atmospheres are likely to occur in normal operation; or
  - ii. explosive gas atmospheres may exist frequently because of repair or maintenance operations or because of leakage; or
  - iii. the location is adjacent to a Class I, Zone 0 location, from which explosive gas atmospheres could be communicated.
- Zone 2 – Class I locations in which:
  - iv. explosive gas atmospheres are not likely to occur in normal operation and if they do occur they will exist for a short time only; or
  - v. flammable volatile liquids, flammable gases or vapours are handled, processed or used, but in which liquids, gases or vapours are normally confined within closed containers or closed systems from which they can escape only as a result of accidental rupture or breakdown of the containers or systems or the abnormal operation of the equipment by which the liquids or gases are handled, processed or used; or
  - vi. explosive gas atmospheres are normally prevented by adequate ventilation, but they may occur as a result of failure or abnormal operation of the ventilation system; or
  - vii. the location is adjacent to a Class I, Zone 1 location from which explosive gas atmospheres could be communicated, unless such communication is prevented by adequate positive-pressure ventilation from a source of clean air, and effective safeguards against ventilation failure are provided.

#### Class I – Equipment

Electrical equipment that is approved for use in Class I hazardous location areas (HLAs) is referred to as explosion proof or flameproof. What this designation means is that the equipment has been designed and manufactured to ensure that it will not become a source of ignition when used in a Class I, gas and vapour HLA.

All explosion-proof equipment is clearly identified by either:

- a “Class I Location” marking (Division System); or
- a “Type of protection ‘d’ ” marking (IEC Zone System).

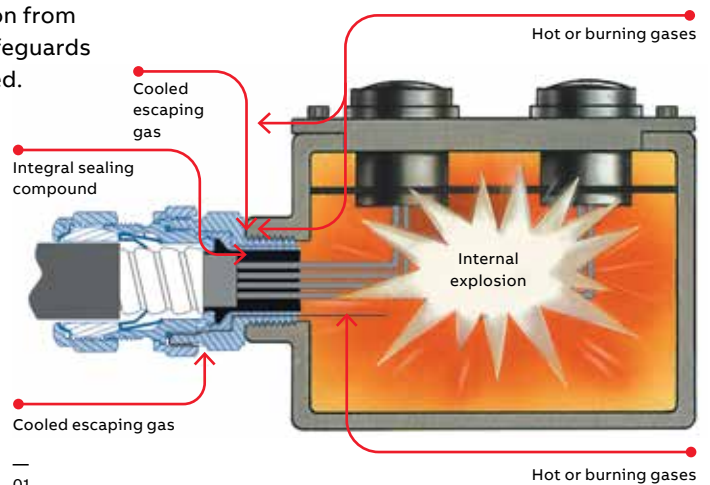

## Hazardous locations – CEC classifications

### Class I



#### Gas group designations

Two systems of groupings for gases are included in the 1998 CEC: the pre-1998 division gas groups consisting of Groups A, B, C and D; and the IEC system consisting of Groups IIA, IIB and IIC. Both systems are accepted by the CEC.

Comparison of hazardous location gas group designations from most restrictive to least restrictive

Typical gas hazard	Division gas groups	1998 CEC and IEC gas groups
Acetylene	A	
Hydrogen	B	IIC
Ethylene	C	IIB
Propane	D	IIA

#### Division gas groups

##### Group A

acetylene

##### Group B

butadiene, hydrogen, manufactured gases containing more than 30% hydrogen (by volume), propylene oxide

##### Group C

acetaldehyde, cyclopropane, ether, ethylene, unsymmetrical dimethyl hydrazine (UDMH 1, 1-dimethyl hydrazine), hydrogen sulfide

##### Group D

acetone, acrylonitrile, alcohol, ammonia, benzene, benzine, benzol, butane, 1-butanol, 2-butanol, butyl acetate, isobutyl acetate, ethane, ethanol, ethyl acetate, ethylene dichloride, gasoline, heptanes, hexanes, isoprene, methane, methanol, 3-methyl-1-butanol, methyl ethyl ketone, 2-methyl-1-propanol, 2-methyl-2-propanol, naphtha, natural gas, petroleum naphtha, octanes, pentanes, 1-pentanol, propane, 1-propanol, 2-propanol, propylene, styrene, toluene, vinyl acetate, vinyl chloride, xylenes

#### IEC zone gas groups

##### Group IIC

acetylene, carbon disulphide, hydrogen or other gases or vapour of equivalent hazard

##### Group IIB

acrylonitrile, butadiene, diethyl ether, ethylene, ethylene oxide, hydrogen sulfide, propylene oxide, unsymmetrical dimethyl hydrazine (UDMH) or other gases or vapour of equivalent hazard

##### Group IIA

acetaldehyde, acetone, alcohol, ammonia, benzene, benzol, butane, cyclopropane, dichloride, ethylene, gasoline, hexane, isoprene, lacquer solvent vapours, naphtha, natural gas, propane, propylene, styrene, vinyl acetate, vinyl chloride, xylenes or other gases or vapour of equivalent hazard

---

## Hazardous locations – CEC classifications

### Class I

#### **Class II – Dust environments**

Locations which are deemed hazardous due to the presence of combustible or electrical conducting dusts. Class II locations normally require that enclosures and fittings be dust tight.

#### **Class III – Fibers and flyings environments**

Locations which are deemed hazardous due to the presence of easily ignitable fibers or flyings, but in which such fibers or flyings are not likely to be in suspension in the air in sufficient quantities to produce ignitable mixtures.

Class III locations normally require that enclosures and fittings be constructed to minimize the entry of fibers or flyings.

#### **Class II and III – Divisions**

Class II and Class III locations are further subdivided as follows:

- Division 1 – Where the hazardous atmosphere is expected to be present during normal operations on a continuous, intermittent or periodic basis.
- Division 2 – Where volatile, flammable liquids or gases are handled, processed or used, but in which they would normally be confined within closed containers or closed systems from which they can escape only in the event of an accidental rupture or breakdown of the containers or systems.

#### **Class II and III – Dust and particles group designations**

The Canadian Electrical Code (CEC), Part 1 Section 18 – Hazardous Locations defines various groups which have been established for the purpose of testing and approval.

- Group E – Comprising atmospheres containing metal dust including aluminum, magnesium, and their commercial alloys, and other metals of similarly hazardous characteristics.
- Group F – Comprising atmospheres containing carbon black, coal or coke dust.
- Group G – Comprising atmospheres containing flour, starch or grain dust, and other dusts of similarly hazardous characteristics.



## Hazardous locations – Class, zone and division certifications

### Class I

#### IEC Zone System

#### CEC Division (pre-1998) system

	Watertight 10464 Series	Star Teck ST050 to ST400	Star Teck XP STX050 to STX400	Star Teck Extreme STE050 to STE200	Star Teck Extreme STE250 to STE400	Star Teck Extreme XP STEX050 to STEX400
<b>With SC4-KIT-1, SC65 integral sealing compound</b>						
Zone 1 Groups IIC, IIB, IIA	Not certified	Not certified	Certified	Not certified	Not certified	Certified
Division 1 Groups A, B, C, D	Not certified	Not certified	Certified	Not certified	Not certified	Certified
Zone 2 Groups IIC, IIB, IIA	Not certified	Not certified	Certified	Not certified	Not certified	Certified
Division 2 Groups A, B, C, D	Not certified	Not certified	Certified	Not certified	Not certified	Certified
<b>With Class I HLA sealing fitting</b>						
Zone 1 Groups IIC, IIB, IIA	Certified	Certified	Not required since certified with integral seal	Certified	Certified	Not required since certified with integral seal
Division 1 Groups A, B, C, D	Certified	Certified	Not required since certified with integral seal	Certified	Certified	Not required since certified with integral seal
Zone 2 Groups IIC, IIB, IIA	Certified	Certified	Not required since certified with integral seal	Certified	Certified	Not required since certified with integral seal
Division 2 Groups A, B, C, D	Certified	Certified	Not required since certified with integral seal	Certified	Certified	Not required since certified with integral seal

### Classes II and III, Divisions 1 and 2

	Watertight 10464 Series	Star Teck ST050 to ST400	Star Teck XP STX050 to STX400	Star Teck Extreme STE050 to STE200	Star Teck Extreme STE250 to STE400	Star Teck Extreme XP STEX050 to STEX400
Class II Divisions 1, 2 Groups E, F, G	Certified	Certified	Certified	Certified	Certified	Certified
Class III Divisions 1, 2 Enclosure Type 6P (immersion)	Certified	Certified	Certified	Certified	Certified	Certified
Enclosure Type 6P (immersion)	Not certified	Not certified	Not certified	Certified	Not certified	Not certified
Enclosure Type 4 (immersion)	Certified	Certified	Certified	Certified	Certified	Certified

### Comparison of Division and IEC Zone Systems

Class I	Division System	Zone System	Notes
Gases and vapours	Division 1	Zone 0	Zone 0 locations are a small percentage of all hazardous locations.
	Division 1	Zone 1	While the wiring practices and acceptable products differ, Class I, Division 1 locations encompass both Zones 0 and 1.
	Division 2	Zone 2	Zone 2 and Division 2 are essentially the same.

## Quick reference



### Teck fittings

Cable hub size	Star Teck (pp. A14–A15)	Star Teck XP (pp. A16–A17)	Star Teck Extreme (pp. A18–A20)	Star Teck Extreme XP (pp. A21–A24)	Watertight 10464 Series (p. A29)
14/2	ST050-464	STX050-464	STE050	STEX075	10464
14/3	ST050-464	STX050-464	STE050	STEX075	10464
14/4	ST050-464	STX050-464	STE050	STEX075	10464
14/6	ST050-465	STX075-465	STE050	STEX075	10465-TB
14/8	ST050-466	STX075-466	STE050	STEX075	10466
14/10	ST075-467	STX075-467	STE075	STEX075	10467
14/20	ST100-469	STX100-468	STE100	STEX100	10469
12/2	ST050-464	STX050-464	STE050	STEX075	10464
12/3	ST050-464	STX050-464	STE050	STEX075	10464
12/4	ST050-465	STX075-465	STE050	STEX075	10465-TB
10/2	ST050-464	STX050-464	STE050	STEX075	10464
10/3	ST050-465	STX075-465	STE050	STEX075	10465-TB
10/4	ST050-465	STX075-465	STE050	STEX075	10465-TB
8/3	ST075-467	STX100-467	STE075	STEX100	10466
8/4	ST075-467	STX100-467	STE075	STEX100	10467
6/3	ST075-468	STX100-468	STE075	STEX100	10468
6/4	ST100-469	STX125-469	STE100	STEX125	10468
4/3	ST100-469	STX125-469	STE100	STEX125	10469
3/3	ST100-469	STX125-469	STE100	STEX125	10469
2/3	ST125-470	STX150-470	STE125	STEX125	10469
1/3	ST125-550	STX150-550	STE125	STEX150	10470
1/0/3	ST125-550	STX150-550	STE150	STEX150	10470
2/0/3	ST150-472	STX200-472	STE150	STEX200	10471
3/0/3	ST150-472	STX200-472	STE150	STEX200	10471
4/0/3	ST200-551	STX200-473	STE200	STEX200	10472
250/3	ST200-474	STX200-474	STE200	STEX250	10473
300/3	ST200-474	STX200-474	STE200	STEX250	10474
350/3	ST200-475	STX250-475	STE200	STEX250	10474
400/3	ST250-477	STX250-475	STE250	STEX300	10475
500/3	ST250-478	STX300-478	STE250	STEX300	10476
600/3	ST300-479	STX300-479	STE300	STEX300	10477
750/3	ST300-480	STX350-480	STE300	STEX350	10478

\*For reference only. Suggested cable size may vary with cable manufacturer specifications

## Star Teck (ST) series fittings for Teck and ACWU cable

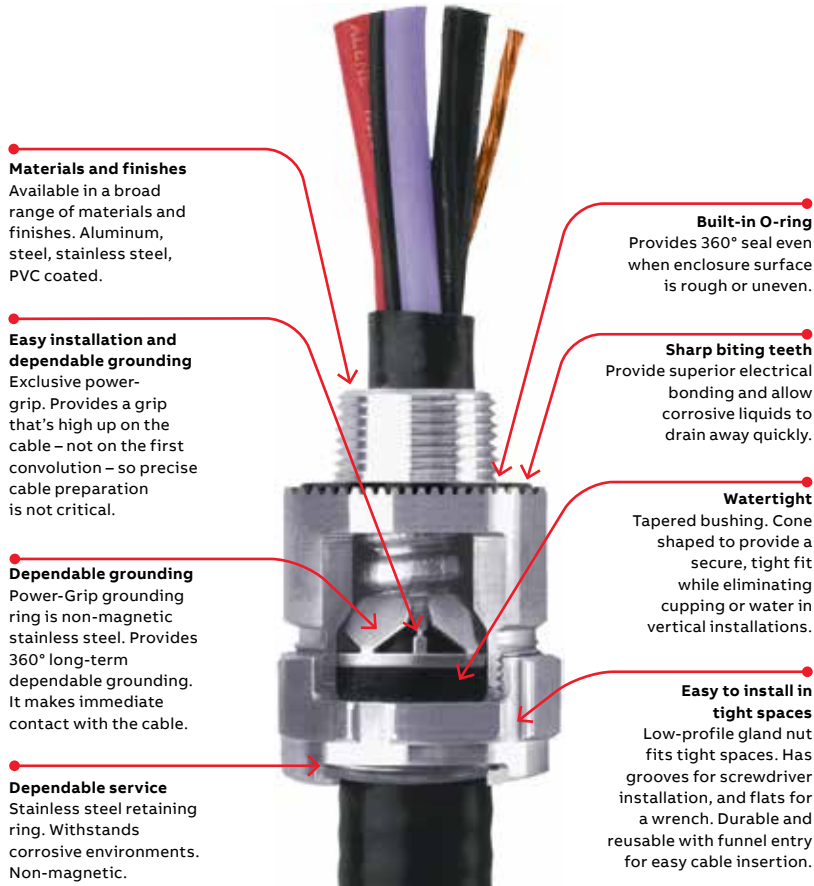

### Suggested specifications for metal-clad cable or Teck cable fittings in hazardous locations:

1. All metal-clad cable fittings for jacketed and non-jacketed interlocked armour cable, continuous corrugated cable or Teck cable shall be approved by a nationally recognized testing laboratory, inspection agency or product evaluation organization.
2. Where corrugated-jacketed, metal-clad cable exposed to intermittent or continuous moisture is terminated into a threaded opening, the fitting shall be watertight type furnished with:
  - a. an elastomeric beveled bushing.
  - a funnel entry, splined gland nut.
  - a non-magnetic, stainless steel grounding device with dual grounding action.
  - a taper threaded hub.
  - a hexagonal body and gland nut as manufactured by ABB (aluminum series ST050-464).
  - a built in sealing O-ring on hub side.
3. With single-conductor cable and/or in corrosive environments, aluminum fittings such as ABB series ST050-464 shall be installed. Where explosion-proof or dust-ignition-proof boxes are required by the code, Star Teck fittings must be used in conjunction with an approved sealing fitting.

### Easy installation

- 01 Prepare cable
- 02 Insert cable
- 03 Tighten gland nut



01



02



03

### Warning:

Always ensure that the system is de-energized before performing any installation.

## Star Teck (ST) series fittings for Teck and ACWU cable



**01 Star Teck (ST series)**  
Star Teck cable fittings are designed to accommodate a broad range of cables, thereby minimizing the possibility of mismatched cables and fittings in the field. They are available in hub sizes from ½ to 4 inches, and will handle outer jacket diameters from 0.525 to 4.340 inches.

Cat. no.	Hub size (in.)	Range over jacket (in.)		Dimensions (in.)		
		min.	max.	A	B*	C
ST038-461S†	¾	0.344	0.535	0.344	2.020	0.995
ST050-462	½	0.525	0.650	0.390	2.020	1.224
ST050-464	½	0.600	0.760	0.480	2.020	1.363
ST050-465	½	0.725	0.885	0.607	2.133	1.633
ST050-466	½	0.825	0.985	0.607	2.133	1.633
ST075-467	¾	0.880	1.065	0.809	2.450	2.080
ST075-468	¾	1.025	1.205	0.809	2.450	2.080
ST100-469	1	1.187	1.375	1.034	2.601	2.230
ST125-470	1¼	1.350	1.625	1.177	3.282	2.824
ST125-550	1¼	1.500	1.625	1.365	3.282	2.824
ST125-471	1¼	1.600	1.875	1.365	3.282	2.824
ST150-472	1½	1.700	1.965	1.552	3.620	3.260
ST150-473	1½	1.900	2.187	1.595	3.620	3.260
ST200-551	2	1.900	2.187	1.710	3.640	3.620
ST200-474	2	2.100	2.375	1.990	3.640	3.620
ST200-475	2	2.300	2.565	2.052	3.640	4.020
ST200-476	2	2.500	2.750	2.052	3.640	4.020
ST250-477	2½	2.380	2.640	2.255	4.700	4.750
ST250-478	2½	2.580	2.840	2.455	4.700	4.750
ST300-479	3	2.790	3.060	2.655	4.700	5.050
ST300-480	3	3.000	3.270	2.885	4.790	5.480
ST300-481	3	3.210	3.480	3.057	4.790	5.480
ST350-482	3½	3.420	3.690	3.285	4.790	5.980
ST350-483	3½	3.610	3.870	3.455	4.790	5.980
ST400-484	4	3.810	4.030	3.625	4.840	6.435
ST400-485	4	3.965	4.185	3.770	4.840	6.435
ST400-486	4	4.120	4.340	3.935	4.840	6.435

\* Approximate dimension before installation  
† Only available in steel

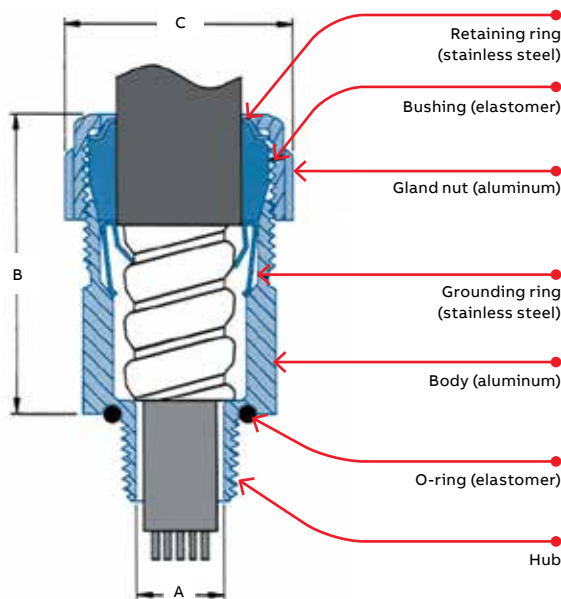

### Materials

- **Aluminum:** The catalogue numbers listed at left relate to aluminum fittings. The body and gland nut on hub sizes ½ to 1 inch are machined from copper-free bar stock and 1¼ to 4 inches are made of cast copper-free aluminum.
- **Steel:** To order a steel or malleable iron fitting, add the suffix “S” to the catalogue number (example ST050-464S). The body and gland nut on hub sizes ½ to 1 inch are made of steel and 1¼ to 4 inches are made of malleable iron. Plating is electro-deposited zinc.
- **Stainless steel:** To order a 316 stainless steel fitting, add the suffix “SS” to the catalogue number (example ST050-464SS). Only available for ½ to 2 inch hub sizes.
- **PVC-coated aluminum and steel:** To order, add the suffix “PVC” to the catalogue number (example ST050-464PVC or ST050-464SPVC).

Note - When using fittings on single-conductor cable, aluminum fittings and aluminum locknuts must be used.

### Certifications

- **Type HLA.** CSA Certified Class II, Divisions 1 and 2, Groups E, F, and G; Class III and Enclosure Type 4, Type 4X, Classes I, II and III. Suitable for Class I Division 1 locations when used in combination with a certified Class I sealing fitting. Also suitable for Class I Division 2 when installed in accordance with the applicable electrical code.
- **Complies with IEC requirements for Class I, Zones 1 and 2,** when used in combination with a certified Class I hazardous location sealing fitting.
- **UL Listed Class I, Division 2; Class II, Division 2 and Class III.** Meets sealing requirements for type 4 enclosures. PVC-coated fittings are only approved for ordinary location areas (OLA).

## Star Teck XP (STX) hazardous location series fittings for Teck cable

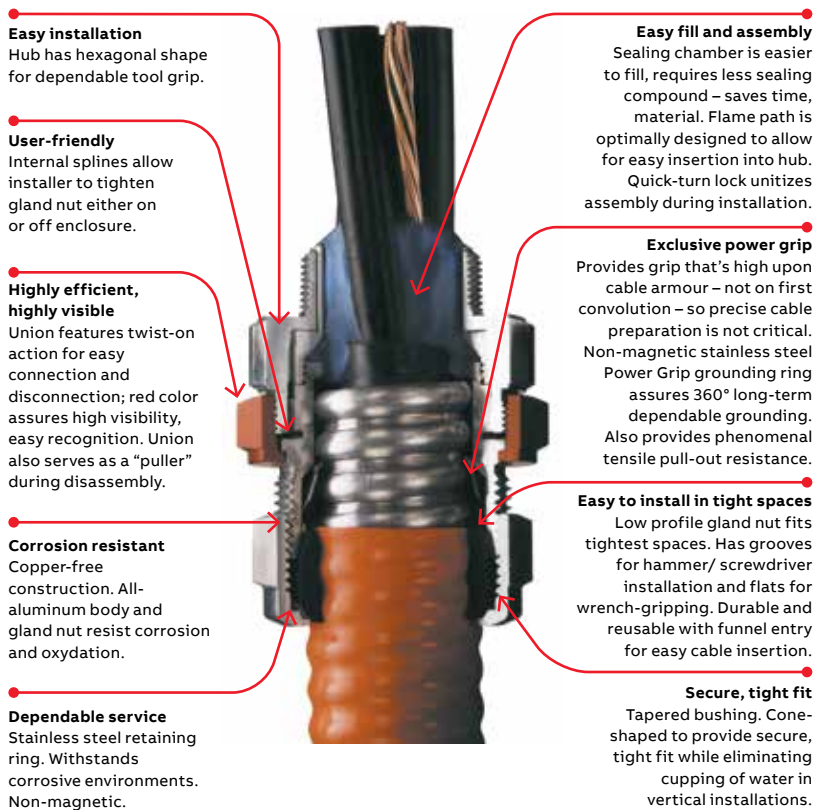

### Suggested specifications for metal-clad cable or Teck cable fittings in hazardous locations:

- All metal-clad cable fittings for jacketed and non-jacketed interlocked armour cable, continuous corrugated cable or Teck cable shall be approved by a nationally recognized testing laboratory, inspection agency or product evaluation organization.
- Where corrugated-jacketed, metal-clad cable exposed to intermittent or continuous moisture is terminated into a threaded opening, the fitting shall be watertight type furnished with:
  - an elastomeric beveled bushing.
  - a funnel entry, splined gland nut.
  - a non-magnetic, stainless steel grounding device with dual grounding action.
  - a taper threaded hub.
  - a hexagonal body and gland nut as manufactured by ABB, STX050-464.
- With single conductor cable and/or in corrosive environments, aluminum connectors such as ABB series STX050-464 shall be installed.
- In hazardous location applications, the fitting shall be of the integral seal type with metal-to-metal contact construction such as ABB Star Teck XP series. Sealing of multi-conductor or shielded cables shall be accomplished with a liquid-type polyurethane compound such as ABB series SC4-KIT-1. Putty-type sealing compound such as ABB series SC65 may be used for other applications.
- The fitting must:
  - Provide an environmental seal around the outer jacket of the cable and electrically bond the fitting to the cable armour prior to potting the explosion-proof seal.
  - Allow the possibility of disconnection without disturbing the environmental seal, the electrical bonding or the explosion-proof seal.

### Easy installation

- 01 Prepare cable
- 02 Install Star Teck XP on cable
- 03 Tighten gland nut
- 04 Pot cable (using liquid or putty)
- 05 Install hub on enclosure
- 06 Insert cable and tighten red union



01



02



03



04



05



06



## Star Teck XP (STX) hazardous location series fittings for Teck cable



**01 Series Star Teck XP (STX)**  
Star Teck XP cable fittings are designed to accommodate a broad range of cables, thereby minimizing the possibility of mismatched cables and fittings in the field. They are available in hub sizes from ½ to 4 inches, and will handle outer jacket diameters from 0.525 to 4.185 inches.



Cat. no.	Hub Size (in.)	Max. vol. of sealing compound (cc)	Range over jacket (in.)		Dimensions (in.)		
			min.	max.	A	B*	C
STX050-462	½	5	0.525	0.650	0.395	2.50	1.63
STX050-464	½	5	0.600	0.760	0.485	2.50	1.63
STX075-465	¾	8	0.725	0.885	0.607	2.62	1.82
STX075-466	¾	8	0.825	0.985	0.715	2.62	1.82
STX100-467	1	16	0.880	1.065	0.750	2.83	2.30
STX100-468	1	16	1.025	1.205	0.895	2.83	2.30
STX125-469	1¼	23	1.187	1.375	1.057	3.05	2.51
STX150-470	1½	43	1.350	1.625	1.177	3.76	3.26
STX150-550	1½	43	1.500	1.625	1.365	3.76	3.26
STX150-471	1½	43	1.600	1.875	1.465	3.76	3.26
STX200-472	2	72	1.700	1.965	1.552	4.05	3.62
STX200-473	2	72	1.900	2.187	1.752	4.05	3.62
STX200-474	2	72	2.100	2.375	1.990	4.15	4.02
STX250-475	2½	147	2.300	2.565	2.180	4.31	4.58
STX250-476	2½	147	2.500	2.750	2.360	4.31	4.58
STX300-478	3	286	2.580	2.840	2.455	5.64	5.10
STX300-479	3	286	2.790	3.060	2.655	5.80	5.33
STX350-480	3½	366	3.000	3.270	2.859	6.32	5.79
STX350-481	3½	366	3.210	3.480	3.057	6.32	5.79
STX400-482	4	614	3.420	3.690	3.285	6.63	6.19
STX400-483	4	614	3.610	3.870	3.455	6.63	6.19
STX400-484	4	614	3.810	4.030	3.625	7.09	6.90
STX400-485	4	614	3.965	4.185	3.770	7.09	6.90

\* Approximate dimension before installation.  
Note - Sealing compound not included. Order separately.

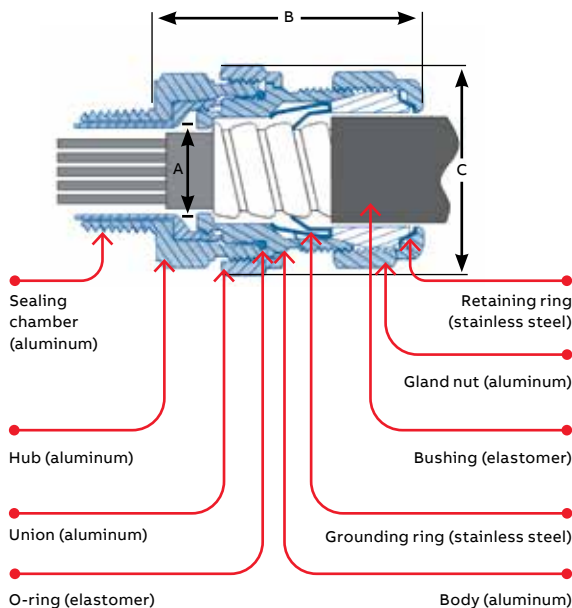

### Materials

- Aluminum: The catalogue numbers listed at left relate to aluminum fittings.
- Steel: To order a steel fitting, add the suffix "S" to the catalogue number (example STX050-464S).

### Certifications

- Type HLA. CSA Certified Class I, Divisions 1 and 2, Groups A, B, C and D; Class II, Divisions 1 and 2; Groups E, F and G; Class III, SL (integral seal) and Enclosure Type 4 and 4X. Complies with IEC requirements for Class 1, Zones 1 and 2, Groups IIC, IIB and IIA.
- UL Listed for ½ through 3 inches when used with putty or liquid type compound: Class 1, Divisions 1 and 2, Groups A, B, C and D; Class II, Division 2, Groups F and G; Class III and Enclosure Type 4 and 4X.
- UL Listed for 3½ and 4 when used with putty or liquid type compound: Class 1, Divisions 1 and 2, Groups B, C and D; Class II, Division 2, Groups F and G; Class III and Enclosure Type 4 and 4X.

### Sealing compounds

Cat. no.	Description	Volume (cubic centimeter)
SC4-KIT-1	Liquid-type sealing compound (includes pouch of sealing compound with integral spout and fiber damming material).	50

Cat. no.	Description	Volume (cubic centimeter)
SC65	Putty-type sealing compound (cut-to-length stick)	34

For more details, refer to the installation/instruction sheet.

**Suitable for use on cables with a maximum of four conductors (including ground).** We do not recommend SC65 for use with shielded cables. Quantity of compound required will vary according to cable conductor fill.

Note - ABB hazardous locations fittings with integral seals (STX, STEX and HLT series) are UL and CSA certified only when used with SC4-KIT-1 or SC65 sealing compounds. No other sealing compounds have been tested, certified or listed.

## Star Teck Extreme (STE) series fittings for Teck cable and ACWU cable

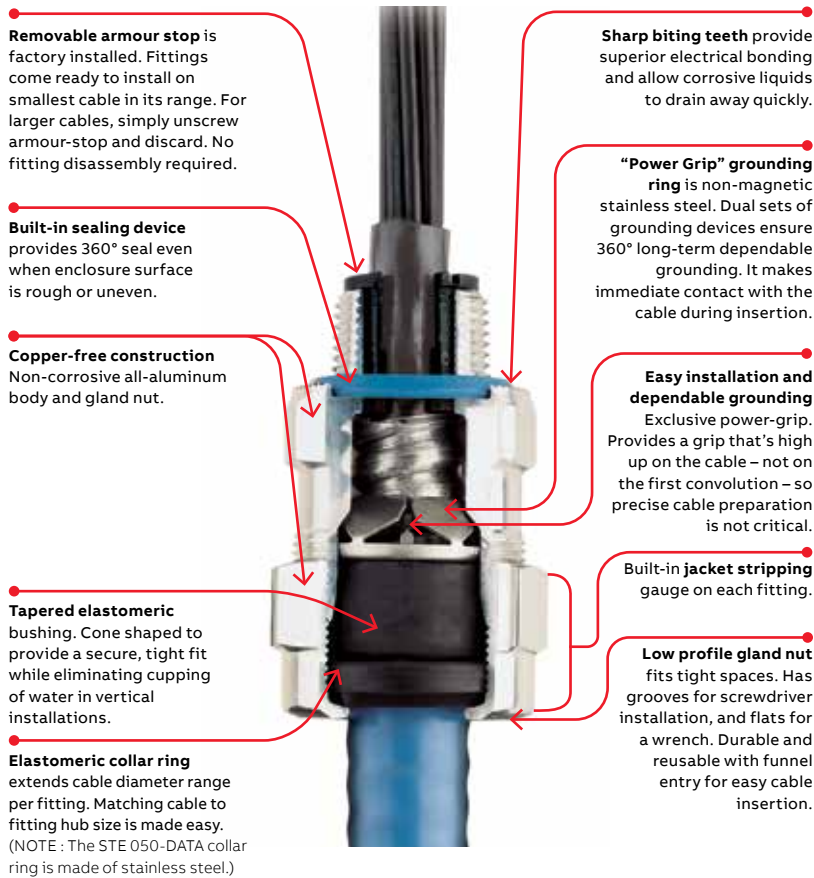

### Suggested specifications for metal-clad cable or Teck cable fittings in hazardous locations:

1. All metal-clad cable fittings for jacketed and non-jacketed interlocked armour cable, continuous corrugated cable or Teck cable shall be approved by a nationally recognized testing laboratory, inspection agency or product evaluation organization.
2. Where corrugated-jacketed, metal-clad cable exposed to intermittent or continuous moisture is terminated into a threaded opening, the fitting shall be watertight type furnished with:
  - a. an elastomeric beveled bushing.
  - b. a funnel entry, splined gland nut.
  - c. a non-magnetic, stainless steel grounding device with dual grounding action.
  - d. a taper threaded hub.
  - e. a hexagonal body and gland nut as manufactured by ABB (aluminum series STE050).
3. A synthetic rubber sealing device shall be captivated in a shoulder groove providing optimized sealing even on irregular surfaces. The configuration shall also prevent over-compression of the seal such as ABB series STE050, by incorporating a shoulder groove.
4. With single-conductor cable and/or in corrosive environments, aluminum fittings such as ABB series STE050 shall be installed.
5. All metal-clad cable fittings, for jacketed and non-jacketed interlocked armour cable, shall provide external bonding/grounding teeth capable of penetrating surface finishes to contact enclosure base metal (ABB series STE050).
6. All metal-clad cable fittings, for jacketed and non-jacketed interlocked armour cable, shall incorporate an easily removable armour stop, not requiring fitting disassembly, ensuring proper positioning of the cable armour during cable termination (ABB series STE050).

### Easy installation

- 01 Prepare cable
- 2a Insert cable
- 2b For larger cables, unscrew and discard armour stop.
- 03 Tighten gland nut



01



2a



2b



03

### Warning:

Always ensure that the system is de-energized before performing any installation.

# Star Teck Extreme (STE) series fittings for Teck cable and ACWU cable



Star Teck Extreme fittings are designed to accommodate a broad range of cables and fittings in the field. Available in hub sizes from ½ to 4 in., Star Teck Extreme fittings will terminate outer jacket diameters from 0.500 to 4.340 in.

Cat. no.	Hub size (in.)	Strip length (in.)	Gland torque (lb-in.)	Range over jacket (in.)		Range over armour (in.)		A1 throat dia. min. (in.) w/ armour stop	A2 throat dia. min. (in.) w/o armour stop	B* overall (in.)	C max. O.D. (in.)
				Min.	Max.	Min.	Max.				
STE050-DATA	½	⅞	300	0.500	0.700	0.410	0.610	0.375	0.515	2.100	1.360
STE050	½	1¼	300	0.600	0.985	0.520	0.895	0.505	0.617	2.520	1.630
STE075	¾	1¼	600	0.860	1.205	0.780	1.125	0.645	0.819	2.840	2.080
STE100	1	1¼	700	0.950	1.375	0.870	1.295	0.785	1.044	3.020	2.300
STE125	1¼	1¾	1 000	1.150	1.625	0.990	1.465	0.970	1.250	4.010	2.820
STE150	1½	1¾	1 200	1.440	1.965	1.280	1.805	1.260	1.562	4.290	3.250
STE200	2	1¾	1 600	1.825	2.375	1.665	2.215	1.645	1.995	4.120	3.600
STE250	2½	2½	1 600	2.265	2.840	2.105	2.680	2.075	2.424	5.670	4.750
STE300	3	2½	1 600	2.670	3.270	2.545	3.145	2.531	2.890	5.780	5.400
STE350	3½	2½	1 600	3.220	3.870	3.090	3.640	3.065	3.414	5.740	5.900
STE400	4	2½	1 600	3.665	4.340	3.550	4.225	3.525	3.914	5.790	6.400

\* Approximate dimension before installation.

### Materials

- Aluminum: The above listed catalogue numbers relate to aluminum fittings.
- Steel: The body and gland nut on hub sizes ½ to 1½ inch are made of steel. The body and gland nut on 2- to 4-inch hub sizes are made of malleable iron. To order a steel fitting, add the suffix "S" to the catalogue number (example STE050S).

### Certifications

- Type HLA. CSA Certified Class II, Divisions 1 and 2, Groups E, F, and G; Class III and Enclosure ½ to 2 Type 4, 4X and 6P, 2½ to 4 Type 4 and 4X, Classes I, II and III. Suitable for Class I Division 1 locations when used in combination with a certified Class I sealing fitting. Also suitable for Class I Division 2 when installed in accordance with the applicable electrical code. Complies with IEC requirements for Class 1, Zones 1 and 2, when used in combination with a certified Class I hazardous location sealing fitting.
- UL listed for metal-clad cable, Type 6P. STE050-DATA is UL listed with cables from 0.592 to .693 in. over jacket.

Note - To order fittings complete with aluminum Bond Star locknut and lug, add the suffix "GRL" to the catalogue number (example STE050GRL). For complete details refer to pages A21-A22 of this section.

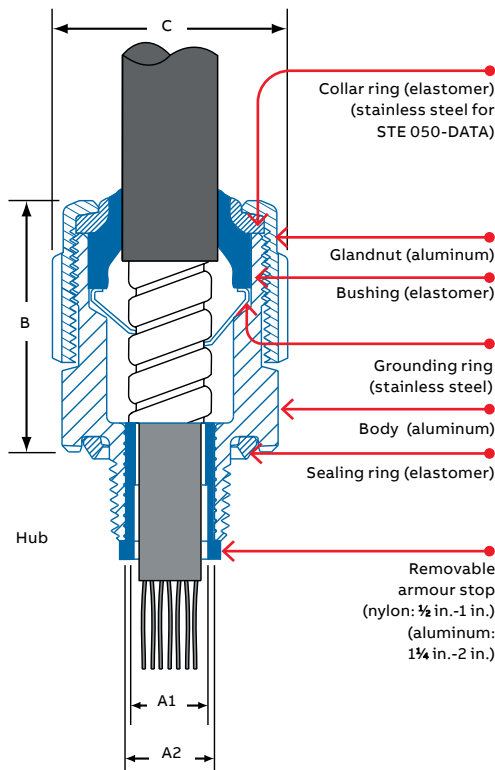

## Star Teck Extreme (STE) series fittings for Teck cable and ACWU cable

### Broadest range of Teck cable diameters per hub size

Star Teck Extreme cat. no.	Star Teck cat. no.	Hub size (NPT) (in.)	Range over jacket (in.) min. - max.
Eleven catalogue numbers cover the range from 0.500 to 4.340 inches.			
v	ST038-461S	3/8	0.344 – 0.535
STE050-DATA	–	1/2	0.500 – 0.700
	ST050-462	1/2	0.525 – 0.650
	ST050-464	1/2	0.526 – 0.760
STE050 0.600 – 0.985 in.	ST050-462	1/2	0.525 – 0.650
	ST050-464	1/2	0.526 – 0.760
	ST050-465	1/2	0.725 – 0.885
	ST050-466	1/2	0.825 – 0.985
STE075 0.860 – 1.205 in.	ST075-467	3/4	0.880 – 1.065
	ST075-468	3/4	1.250 – 1.205
STE100 0.950 – 1.375 in.	ST075-467	3/4	0.880 – 1.065
	ST075-468	3/4	1.250 – 1.205
	ST100-469	1	1.187 – 1.375
	ST125-470	1 1/4	1.350 – 1.625
STE125 1.150 – 1.625 in.	ST075-468	3/4	1.250 – 1.205
	ST100-469	1	1.187 – 1.375
	ST125-470	1 1/4	1.350 – 1.625
	ST125-550	1 1/4	1.500 – 1.625
	ST125-471	1 1/4	1.600 – 1.875
STE150 1.440 – 1.965 in.	ST125-470	1 1/4	1.350 – 1.625
	ST125-550	1 1/4	1.500 – 1.625
	ST125-471	1 1/4	1.600 – 1.875
	ST150-472	1 1/2	1.700 – 1.965
	ST150-473	1 1/2	1.900 – 2.187
	ST200-551	2	1.900 – 2.187

Tinted cells are additional sizes.

Star Teck Extreme cat. no.	Star Teck cat. no.	Hub size (NPT) (in.)	Range over jacket (in.) min. - max.
Eleven catalogue numbers cover the range from 0.500 to 4.340 inches.			
STE200 1.825 – 2.375 in.	ST150-472	1 1/2	1.700 – 1.965
	ST150-473	1 1/2	1.900 – 2.187
	ST200-551	2	1.900 – 2.187
	ST200-474	2	2.100 – 2.375
STE250 2.265 – 2.840 in.	ST200-475	2	2.300 – 2.565
	ST200-474	2	2.100 – 2.375
	ST200-475	2	2.300 – 2.565
	ST200-476	2	2.500 – 2.750
	ST250-477	2 1/2	2.380 – 2.640
STE300 2.670 – 3.270 in.	ST250-478	2 1/2	2.580 – 2.840
	ST300-479	3	2.790 – 3.060
	ST250-478	2 1/2	2.580 – 2.840
	ST300-479	3	2.790 – 3.060
STE350 3.220 – 3.870 in.	ST300-480	3	3.000 – 3.270
	ST300-481	3	3.210 – 3.480
	ST300-480	3	3.000 – 3.270
	ST300-481	3	3.210 – 3.480
	ST350-482	3 1/2	3.420 – 3.690
STE400 3.665 – 4.340 in.	ST350-483	3 1/2	3.610 – 3.870
	ST400-484	4	3.810 – 4.030
	ST350-483	3 1/2	3.610 – 3.870
	ST400-484	4	3.810 – 4.030
	ST400-485	4	3.965 – 4.185
	ST400-486	4	4.120 – 4.340

## Star Teck Extreme XP (STEX) hazardous location series fittings for Teck cable

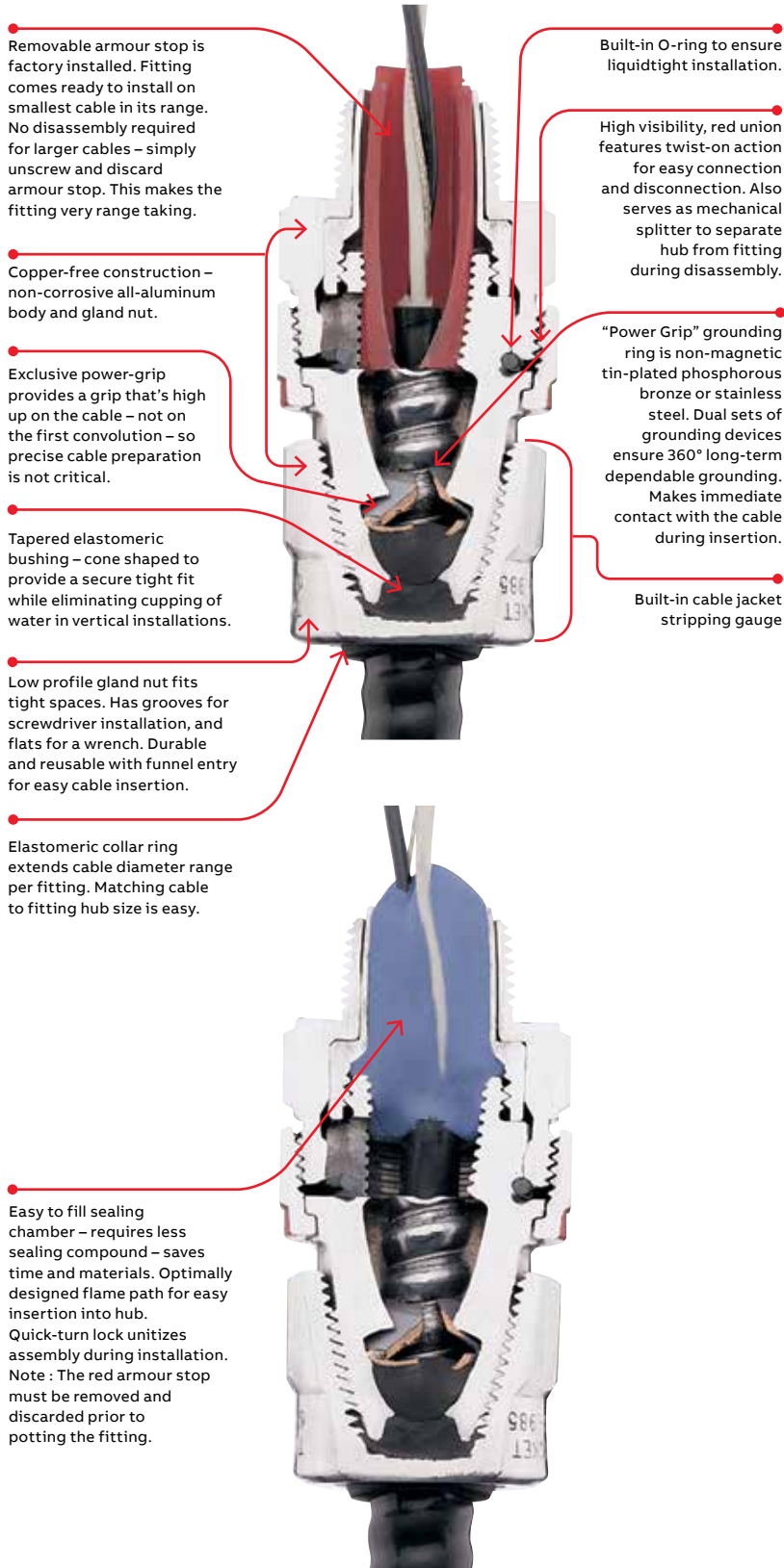

### Suggested specifications for metal-clad cable or Teck cable fittings in hazardous locations:

1. All metal-clad cable fittings for jacketed and non-jacketed interlocked armour cable, continuous corrugated cable or Teck cable shall be approved by a nationally recognized testing laboratory, inspection agency or product evaluation organization.
2. Where corrugated-jacketed, metal-clad cable exposed to intermittent or continuous moisture is terminated into a threaded opening, the fitting shall be watertight type furnished with:
  - a. an elastomeric beveled bushing.
  - a funnel entry, splined gland nut.
  - a non-magnetic, tin-plated phosphorous bronze or stainless steel grounding device with dual grounding fingers.
  - a taper threaded hub.
  - a hexagonal body and gland nut as manufactured by ABB (aluminum series STEX075).
3. With single-conductor cable and/or in corrosive environments, aluminum connectors such as ABB series STE075 shall be installed.
4. In hazardous location applications, the fitting shall be of the integral seal type with metal-to-metal contact construction such as ABB Star Teck Extreme XP series. Sealing of multi-conductor or shielded cables shall be accomplished with a liquid-type polyurethane compound such as ABB series SC4-KIT-1. Putty-type sealing compound such as ABB series SC65 may be used for other applications.
5. The fitting must:
  - a. Provide an environmental seal around the outer jacket of the cable and electrically bond the fitting to the cable armour prior to potting the explosion-proof seal.
  - b. Allow the possibility of disconnection without disturbing the environmental seal, the electrical bonding or the explosion-proof seal.
6. All metal-clad cable fittings, for jacketed and non-jacketed interlocked armour cable, shall incorporate an easily removable armour stop (not requiring fitting disassembly), ensuring proper positioning of the cable armour during cable termination, such as ABB series STEX075.

## Star Teck Extreme XP (STEX) hazardous location series fittings for Teck cable

### Easy installation

- 01 Prepare cable
- 02 Install StarTeck Extreme XP on cable
- 03 Tighten gland nut
- 04 Remove armour stop
- 05 Pot cable using liquid or putty
- 06 Insert hub on enclosure
- 07 Insert cable and tighten red union
- 08 Clean, professional cable terminations on the broadest range of Teck cable diameters.



01



02



03



04



05



06



07



08

### Warning:

Always ensure that the system is de-energized before performing any installation.

## Star Teck Extreme XP (STEX) hazardous location series fittings for Teck cable



Star Teck Extreme fittings are designed to accommodate a broad range of cables and each hub range overlaps the adjacent hub range, thereby minimizing the possibility of mismatched cables and fittings in the field. They are available in hub sizes from ½ to 4 inches, and will handle outer jacket diameters from 0.525 to 3.870 inches.

Cat. no.	Hub size (in.)	Range over jacket (in.)		Range over armour (in.)		A1 Throat dia min. (in. w/ armour stop)	A2 throat dia. min. (in.) w/o armour stop	B* length (in.)	Max. O.D. (in.)	Compound C req'd (approx.) SC65/SC4-KIT-1 liquid (cc)
		Min.	Max.	Min.	Max.					
STX050-462	½	0.525	0.650	0.415	0.570	-***	0.400	2.500	1.630	5
STX050-464	½	0.600	0.760	0.490	0.680	-***	0.480	2.530	1.630	5
STEX075	¾	0.600	0.985	0.520	0.895	0.500	0.670	3.400	1.820	8
STEX100	1	0.860	1.205	0.780	1.125	0.645	0.825	3.580	2.300	16
STEX125	1¼	0.950	1.375	0.870	1.295	0.829	1.076	3.920	2.510	23
STEX150	1½	1.150	1.625	0.990	1.465	0.953	1.280	5.020	3.260	43
STEX200	2	1.440	1.965	1.280	1.805	1.245	1.565	5.120	3.620	72
STEX250	2½	1.825	2.375	1.665	2.215	1.630	2.000	5.170	4.580	147
STEX300	3	2.265	2.840	2.105	2.680	2.066	2.495	6.610	5.100	286
STEX350	3½	2.670	3.270	2.545	3.145	2.522	2.895	7.380	5.790	366
STEX400	4	3.220	3.870	3.090	3.640	3.060	3.520	7.650	6.190	614

\* Approximate dimension before installation.  
Note - Sealing compound not included. Order separately.

### Materials

- Aluminum: The above listed catalogue numbers relate to aluminum fittings.
- Steel: To order a steel fitting, add the suffix "S" to the catalogue number (example STEX050S).
- Minimum quantities may apply (consult your regional sales office).

### Certifications

- Type HLA. CSA Certified Class I, Divisions 1 and 2, Groups A, B, C and D; Class II, Divisions 1 and 2; Groups E, F and G; Class III, SL (integral seal); hub sizes ½ through 2½ inches - enclosure type 6P; hub sizes 3, 3½ and 4 inches - enclosure type 4. Complies with IEC requirements for Class I, Zones 1 and 2, Groups IIC, IIB and IIA.
- UL Listed for ½ through 2 inch hub sizes when used with putty or liquid type compound: Class 1, Division 2, Groups A, B, C and D; Class II, Divisions 1 and 2, Groups F and G; Class III and enclosure type 6P.
- UL Listed for 3½ and 4 when used with putty or liquid type compound: Class 1, Divisions 1 and 2, Groups B, C and D; Class II, Division 2, Groups F and G; Class III and enclosure type 4.

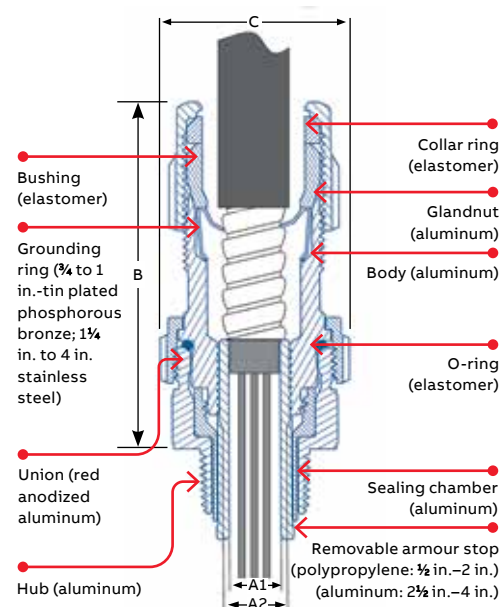

## Star Teck Extreme XP (STEX) hazardous location series fittings for Teck cable

### Sealing compounds

	Cat. no.	Description	Volume (cubic centimeter)
	SC4-KIT-1	Liquid-type sealing compound (includes pouch of sealing compound with integral spout and fiber damming material).	50

	Cat. no.	Description	Volume (cubic centimeter)
	SC65	Putty-type sealing compound (cut-to-length stick)	34

For more details, refer to the installation/instruction sheet.

**Suitable for use on cables with a maximum of four conductors (including ground).** We do not recommend SC65 for use with shielded cables. Quantity of compound required will vary according to cable conductor fill.

Note - ABB hazardous locations fittings with integral seals (STX, STEX and HLT series) are UL and CSA certified only when used with SC4-KIT-1 or SC65 sealing compounds. No other sealing compounds have been tested, certified or listed.



## Star Teck ST90 series fittings - 90-degree Teck fittings



A natural extension to the Star Teck family, the ST90 series for Teck and jacketed armored cables offers innovative design that sets the standard for ease of installation, quality engineering, and for safe and reliable cable termination in challenging industrial environments.

### Features and benefits

- Excellent pullout strength
- Robust metallic construction
- Quick and easy installation without disassembly
- Provides grounding continuity of cable armor
- Splined gland and gripping features for ease of installation
- CSA certified for Class I Division 2, groups E, F and G; Class II and III
- Suitable for Class I Division 1 when used in combination with Class 1 HLA sealing fitting
- Rated TYPE 4/4X and 6P
- Made of copper free aluminum



### The Power-Grip® grounding ring

- Holds cable in place for hands-free tightening
- Superior pullout resistance
- 360° circular grounding
- Stainless steel construction resists corrosion



### Product selection

Values in **bold** are in millimeters and values in (brackets) are in inches

Part no:	Thread (NPT)	Range over jacket		Range over armour		Nominal dimensions					
		Min	Max	Min	Max	A	B	C	D	E	F
ST90-050-464*	1/2	<b>15.24</b>	<b>19.3</b>	<b>13.46</b>	<b>17.27</b>	<b>15.75</b>	<b>64.26</b>	<b>34.16</b>	<b>12.19</b>	<b>97.28</b>	<b>23.37</b>
		(0.600)	(0.760)	(0.530)	(0.680)	(0.620)	(2.530)	(1.345)	(0.480)	(3.830)	(0.92)
ST90-050-466	1/2	<b>19.05</b>	<b>25.02</b>	<b>17.02</b>	<b>22.73</b>	<b>15.75</b>	<b>67.31</b>	<b>40.64</b>	<b>15.75</b>	<b>109.22</b>	<b>21.46</b>
		(0.750)	(0.985)	(0.670)	(0.895)	(0.620)	(2.650)	(1.600)	(0.620)	(4.300)	(0.845)
ST90-075-468	3/4	<b>24.13</b>	<b>30.61</b>	<b>22.10</b>	<b>28.58</b>	<b>15.75</b>	<b>84.58</b>	<b>51.82</b>	<b>20.83</b>	<b>130.30</b>	<b>30.38</b>
		(0.950)	(1.205)	(0.870)	(1.125)	(0.620)	(3.330)	(2.040)	(0.820)	(5.130)	(1.196)
ST90-100-469	1	<b>29.97</b>	<b>34.93</b>	<b>27.69</b>	<b>32.89</b>	<b>20.07</b>	<b>93.98</b>	<b>57.28</b>	<b>26.42</b>	<b>145.29</b>	<b>32.51</b>
		(1.180)	(1.375)	(1.090)	(1.295)	(0.790)	(3.700)	(2.255)	(1.040)	(5.720)	(1.28)

Note: Product must be installed in accordance with applicable national and local electrical codes.

\*ST90-050-464 fitting: TYPE 4 / 4X only

\*\*F dimensions represent inner radius of elbow

### Perfect for tight spaces:

80-90% smaller bend radius than corresponding armored cable

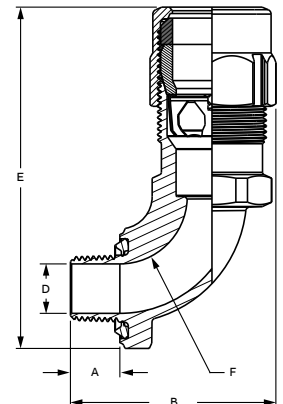
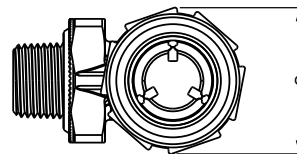
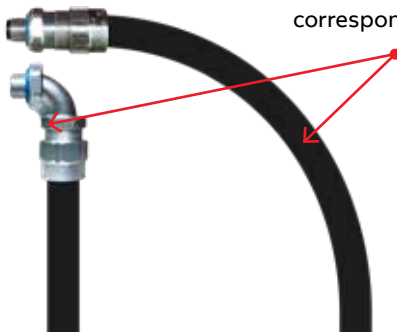

## Bond Star grounding locknut



### Extreme grounding for data and control applications.

For data and control panel applications or any other installation that is highly sensitive to floating voltage differences, the complete range of Star Teck Extreme fittings (½ in. to 4 in. hub sizes) is also available with a 3-position grounding locknut including an open-sided lay-in lug made of tin-plated aluminum. With a #4–14 AWG wire range, the CSA and UL approved grounding lug can be positioned on the most accessible of the three grounding locations on the circumference of the installed grounding locknut. When installation requires multiple incoming cables, each individual lug terminating the connections can be “daisy chain” bonded to the grounding bus, ensuring the same electrical potential throughout the cables.

Bond Star grounding locknuts can also be used with the complete range of ABB Teck cable fittings. To order individually, use the catalogue numbers shown on page A22.

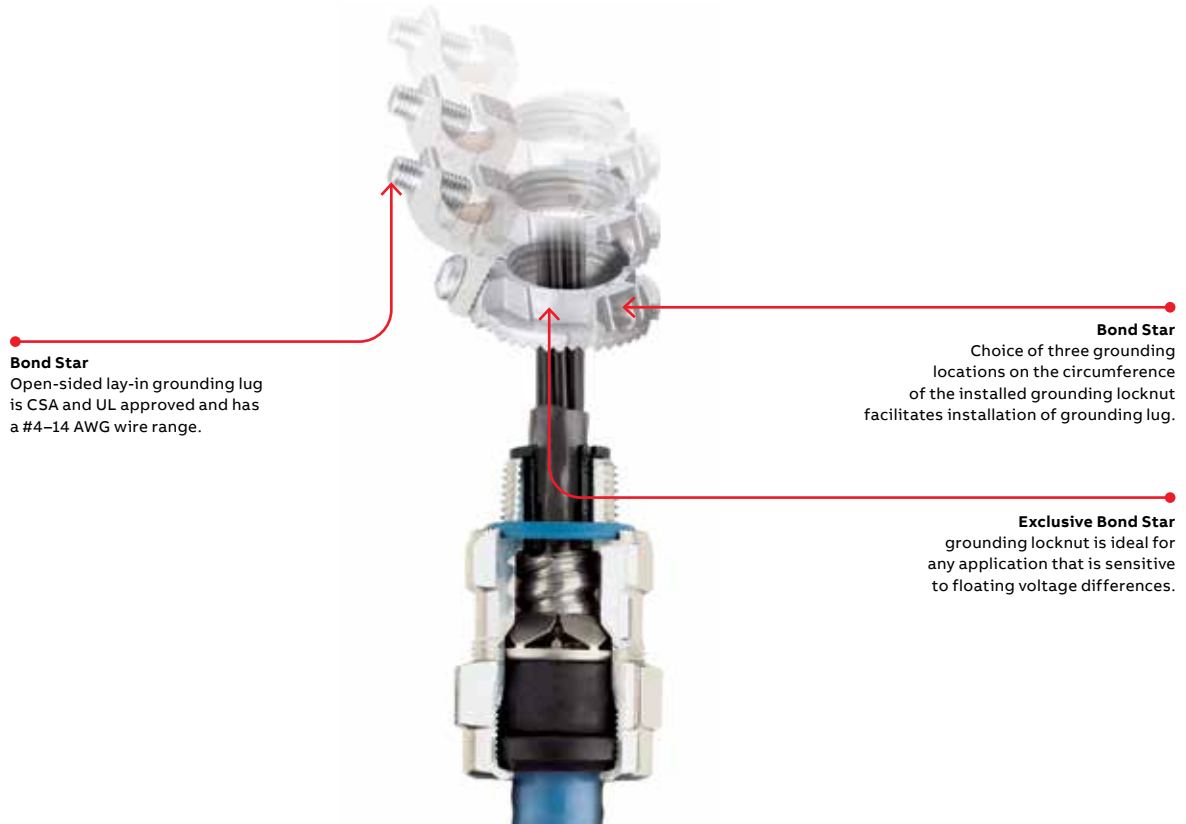

**Bond Star**  
Open-sided lay-in grounding lug is CSA and UL approved and has a #4–14 AWG wire range.

**Bond Star**  
Choice of three grounding locations on the circumference of the installed grounding locknut facilitates installation of grounding lug.

**Exclusive Bond Star**  
grounding locknut is ideal for any application that is sensitive to floating voltage differences.

## Bond Star grounding locknut

### Star Teck Extreme fittings with Bond Star grounding locknut



Cat. no.	Hub size (in.)	Obsoleted items
STE050-DATAGRL	½	STE050-DATAGR
STE050GRL	½	STE050GR
STE075GRL	¾	STE075GR
STE100GRL	1	STE100GR
STE125GRL	1¼	STE125GR
STE150GRL	1½	STE150GR
STE200GRL	2	STE200GR
STE250GRL	2½	STE250GR
STE300GRL	3	STE300GR
STE350GRL	3½	STE350GR
STE400GRL	4	STE400GR

### Bond Star grounding locknut with lay-in-lug



Cat. no.	Size (in.)	Description
L050GRL	½	Locknut with lay-in lug and screw
L075GRL	¾	Locknut with lay-in lug and screw
L100GRL	1	Locknut with lay-in lug and screw
L125GRL	1¼	Locknut with lay-in lug and screw
L150GRL	1½	Locknut with lay-in lug and screw
L250GRL	2½	Locknut with lay-in lug and screw
L300GRL	3	Locknut with lay-in lug and screw
L350GRL	3½	Locknut with lay-in lug and screw
L400GRL	4	Locknut with lay-in lug and screw

### Lay-in lug



Cat. no.	Screw	For hub sizes (in.)
GRL-LUG1032	#10, 32 TPI	½, ¾, 1
GRL-LUG1/4-20	¼, 20 TPI	1¼ 6

## 10464 Series watertight fittings for ACWU cable



Cat. no.	Hub size (in.)	Cable jacket O.D. (in.)		Throat dia. (in.)
		Min.	Max.	
10462*	½	0.562	0.625	0.615
10464	½	0.625	0.760	0.615
10465-TB	½	0.750	0.885	0.615
10466	½	0.875	0.985	0.615
10467	¾	0.880	1.065	0.780
10468	¾	1.055	1.205	0.780
10469	1	1.187	1.375	1.000
10470	1¼	1.375	1.625	1.187
10550	1¼	1.375	1.625	1.400
10471	1¼	1.625	1.875	1.400
10472	1½	1.750	1.965	1.563
10473	1½	1.937	2.187	1.621
10551	2	2.000	2.187	2.000
10474	2	2.156	2.360	2.000
10475	2	2.350	2.565	2.000
10552	2	2.350	2.565	2.092
10476	2	2.535	2.750	2.092
10553	2½	2.535	2.750	2.437
10477	2½	2.735	2.985	2.437
10478	2½	2.970	3.220	2.437
10554	3	2.975	3.125	3.050
10555	3	3.080	3.250	3.050
10479	3	3.210	3.380	3.050
10480	3	3.310	3.480	3.050
10481	3½	3.430	3.620	3.310
10482	3½	3.560	3.750	3.310
10483	3½	3.710	3.870	3.310
10484	4	3.810	4.000	3.560
10485	4	3.930	4.120	3.670
10486	4	4.060	4.250	3.800

Note - When using fittings on single-conductor cable, aluminum fittings and aluminum locknuts must be used.

\*Cat. no. 10462 not UL Listed

### Materials

- Malleable iron: The above listed catalogue numbers relate to malleable iron fittings with a protective grounding sleeve for jacketed metal-clad cable.
- Aluminum: Available up to 2½ inches. To order add suffix "AL" to the catalogue number (example 10478AL).
- PVC-coated aluminum and steel: Contact your regional sales office for availability and ordering information.

### Certifications

- Type HLA. CSA certified Classes I, II and III. These fittings are suitable for Class I hazardous locations when used in combination with a certified Class I hazardous location sealing fitting.
- Type OLA. UL listed. These fittings are suitable for use interlocked jacketed cable, aluminum or steel armour.



## 90° Watertight and non-watertight fittings

### 90° Watertight fittings



	Cat. no.	Hub size (in.)	Neoprene bushing (in.)		Throat dia. (in.)
			Min.	Max.	
	10601-TB	½	0.625	0.760	0.615
	10602-TB	½	0.750	0.885	0.615
	10603	½	0.875	0.985	0.615
	10604-TB	¾	0.880	1.065	0.825
	10605	¾	1.055	1.205	0.825
	10606-TB	1	1.187	1.375	1.000

#### Materials

- Malleable iron: The above listed catalogue numbers relate to malleable iron fittings with a protective grounding sleeve for jacketed metal-clad cable.

#### Certifications

- Type HLA. CSA certified Classes I, II and III. These fittings are suitable for Class I hazardous locations when used in combination with a certified Class I hazardous location sealing fitting.
- Type OLA. UL listed. These fittings are suitable for use with interlocked jacketed cable, aluminum or steel armour.

### Non-watertight fittings

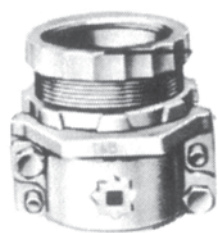

	Cat. no.	Hub size (in.)	Armour O.D. (in.)	
			Min.	Max.
	10000	¾	0.562	0.800
	10001	1	0.687	0.950
	10002-TB	1¼	1.000	1.344
	10003-TB	1½	1.313	1.563
	10004	2	1.563	2.000
	10005	2½	2.000	2.469

- Material: Malleable iron
- Type OLA. UL listed. These fittings are suitable for use with interlocked jacketed cable, aluminum or steel armour.

### Non-watertight fittings



	Cat. no.	Hub size (in.)	Armour O.D. (in.)	
			Min.	Max.
	10000AL	¾	0.562	0.800
	10001AL	1	0.687	0.950
	10002AL	1¼	1.000	1.344
	10003AL	1½	1.313	1.563
	10004AL	2	1.563	2.000
	10005AL	2½	2.000	2.469

- Material: Aluminum
- Type OLA. UL listed. These fittings are suitable for use with interlocked jacketed cable, aluminum or steel armour.

## Tray Star HLT series hazardous location fittings for tray cable

The Canadian Electrical Code states that tray cable in hazardous locations can be used either within the cable tray, or outside the tray – provided there is additional protection. The Tray Star fitting was designed and engineered for either application and comes complete with the bushing, ground cone and sealing ring for different product applications.

### Ease of installation

Installation is quick and easy. When used on metallic liquidtight conduit, the fitting hub size correlates with that of the conduit trade size. (i.e. ½ in. fitting accommodates ½ in. conduit). The bushings, when utilized, are designed to accommodate a broad range of tray cable diameters. Either liquid or putty sealing compound can be used for a positive, gastight seal. The compound is ordered separately to allow for flexibility in making the correct selection for various types of installations. The sealing compounds cure in just a few hours. The Tray Star fitting also has disconnect capability: the cable can be disconnected and reconnected after being sealed.



Outside tray – Tray cable must be protected within conduit and flexible liquidtight metallic conduit. In this case, the connector bushing is simply replaced with a ground cone/sealing ring to terminate the assembly.

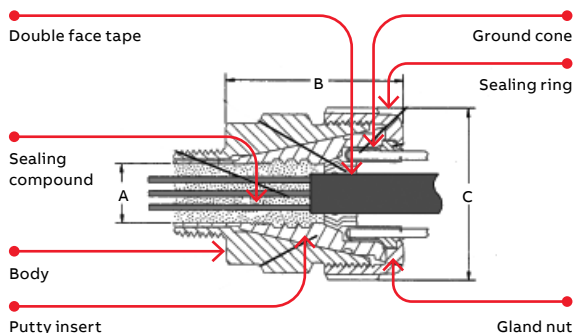

With conduit

The unique hexagonal gland nut is conveniently grooved for screwdriver installation in extremely cramped areas. The gland nut is also clearly identified with the catalogue number and CSA approvals. It is also anodized a red colour to identify it as a hazardous location, tray cable fitting.

### Superior construction

Tray Star fittings have a low-profile compact design and are made of copper-free aluminum for long-lasting trouble-free service. Fittings are precision machined for superior fit and ease of installation.

### Materials

- Aluminum: The catalogue numbers listed on the following page relate to aluminum fittings.

### Certifications

- Type HLA. CSA certified Class I, Division 2, Groups A, B, C and D; Class II, Division 2, Groups E, F and G; Class III, Division 2, enclosure type 4 SL (integral seal).



Inside tray – Used with a neoprene bushing, Tray Star terminates tray cable within the tray itself.

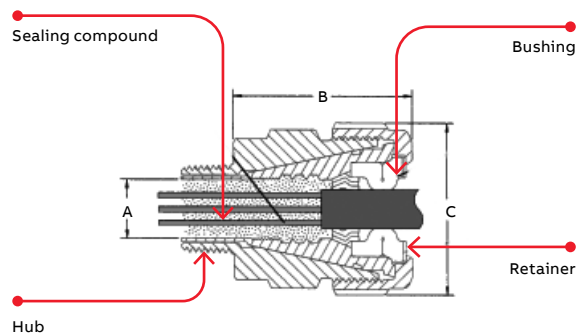

With bushing

## Tray Star HLT series hazardous location fittings for tray cable

### Ordering information



Cat. no.	Hub size (in.)	Range over jacket (in.)		Conduit trade size (in.)	Approx. compound required*		Dimensions (in.)		
		Min.	Max.		Putty / liquid SC65/SC4-KIT-1 (cc)	A Throat dia.	B Overall	C Dim.	
HLT050DATA †	½	0.250	0.310	½	7	0.505	1.870	1.625	
HLT050 †	½	0.300	0.400	½	7	0.505	1.870	1.625	
HLT075 †	¾	0.320	0.570	¾	15	0.707	2.140	2.075	
HLT100 †	1	0.400	0.750	1	23	0.932	2.270	2.290	
HLT125 †	1¼	0.625	1.000	1¼	45	1.263	2.750	2.840	
HLT150 †	1½	0.780	1.200	1½	68	1.493	3.000	3.275	
HLT200 †	2	1.000	1.560	2	112	1.950	3.200	3.640	
4-250TC	2½	1.700	2.200	2½	175	2.250	3.800	4.000	
4-300TC	3	2.150	2.700	3	359	2.750	3.860	4.690	
4-350TC	3½	2.650	3.230	3½	536	3.280	4.100	5.220	
4-400TC	4	3.180	3.790	4	690	3.840	4.000	5.630	

† Not UL Listed

\* Sealing compound not included with HLT-series. Order separately.

SC65 putty supplied with each TC-series fitting. SC4-KIT-1 liquid sealing compound not approved for use with TC-series.

TC-series is suitable for use with tray cable only and cannot be used with conduit.

### Sealing compounds

Cat. no.	Description	Volume (cubic centimeter)
SC4-KIT-1	Liquid-type sealing compound (includes pouch of sealing compound with integral spout and fiber damming material).	50



Cat. no.	Description	Volume (cubic centimeter)
SC65	Putty-type sealing compound (cut-to-length stick)	34



For more details, refer to the installation/instruction sheet.

**Suitable for use on cables with a maximum of four conductors (including ground).** We do not recommend SC65 for use with shielded cables. Quantity of compound required will vary according to cable conductor fill.

Note - ABB hazardous locations fittings with integral seals (STX, STEX and HLT series) are UL and CSA certified only when used with SC4-KIT-1 or SC65 sealing compounds. No other sealing compounds have been tested, certified or listed.

## Silver Grip – TCF series tray-cord fitting

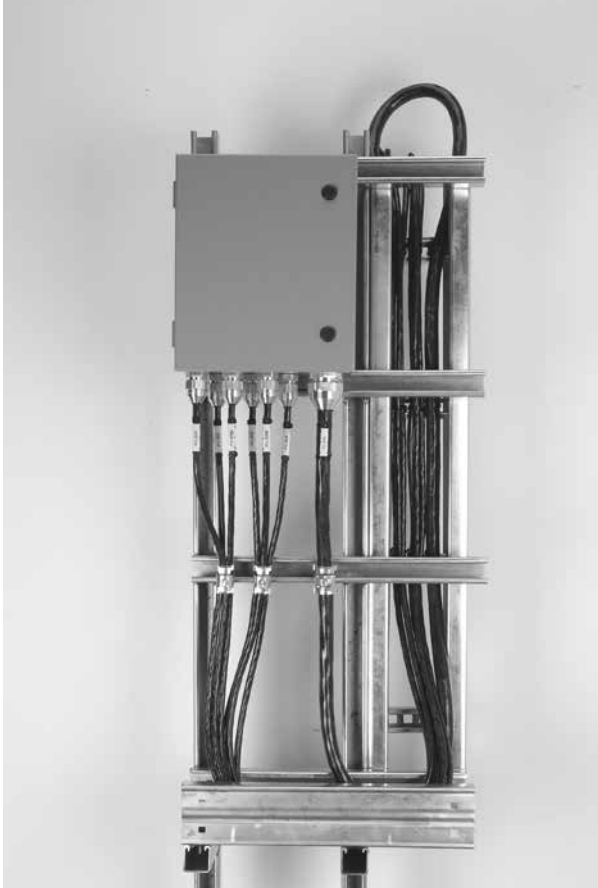

### Applications

#### Tray cable

Complies with IEC requirements for Class I, Zone 2 locations when used with enclosures containing no arcing or sparking devices. For enclosures with arcing or sparking devices, TCF fittings must be used in combination with a certified Class I hazardous location sealing fitting.

#### Portable cord

Complies with IEC requirements for Class I, Zone 1 locations when used with enclosures containing no arcing or sparking devices. For enclosures with arcing or sparking devices, TCF fittings must be used in combination with a certified Class I hazardous location sealing fitting.

- CSA Class 4418-05 Fittings for Hazardous Locations Class I, Zone 1 Ex e II, IP66; Type 4/4X, (CSA)
- CSAus Class 4418-85 Fittings for Hazardous Locations Class I, Zone 1, A Ex e II, IP66; Type 4/4X, (CSAus)

Note: Tray cable is not suitable for use in Zone 1 locations. Portable cord can be used in Zone 1 applications only when installed on portable equipment.

### Utilisation

- For use with unarmored cable types suitable for use in Class I, Zone 1 (e.g. extra hard usage cord)
- Series TCF cable glands, when used with tray cables are suitable to be installed in Class I, Zone 2/Div. 2 classified hazardous location areas according to CEC/NEC wiring method, or subject to local inspection authority having jurisdiction



## Silver Grip – TCF series tray-cord fitting

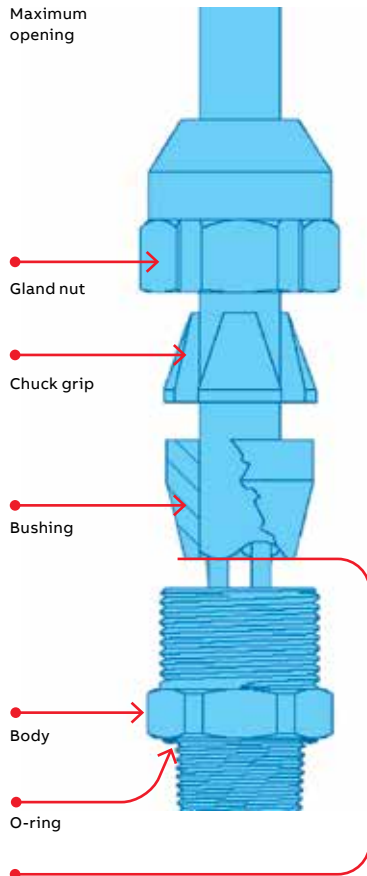

\*When cord will not fit through body, strip cord jacket and trim fillers if required. Insert cable ensuring the outer jacket reaches the end of the bushing as shown. Tighten gland nut onto body

### TCF (tray-cord fittings)



Cat. no. aluminum	Cat. no. stainless steel	Hub size NPT (in.)	Throat diameter (in.)	Minimum cable dia. (in.)	Maximum cable dia. (in.)
TCF050-27AL	TCF050-27SS6	½	0.330	0.150	0.270
TCF050-40AL	TCF050-40SS6	½	0.540	0.250	0.400
TCF050-54AL	TCF050-54SS6	½	0.540	0.400	0.540
TCF050-67AL	TCF050-67SS6	½	0.540*	0.540	0.670
TCF050-78AL	TCF050-78SS6	½	0.540*	0.660	0.780
TCF075-40AL	TCF075-40SS6	¾	0.540	0.250	0.400
TCF075-54AL	TCF075-54SS6	¾	0.540	0.400	0.540
TCF075-67AL	TCF075-67SS6	¾	0.780	0.540	0.670
TCF075-78AL	TCF075-78SS6	¾	0.780	0.660	0.780
TCF075-88AL	TCF075-88SS6	¾	0.765*	0.770	0.880
TCF100-78AL	TCF100-78SS6	1	0.980	0.660	0.780
TCF100-88AL	TCF100-88SS6	1	0.980	0.770	0.880
TCF100-100AL	TCF100-100SS6	1	0.980*	0.870	1.000
TCF100-109AL	TCF100-109SS6	1	0.980	0.940	1.090
TCF125-109AL	–	1¼	1.255	0.890	1.090
TCF125-128AL	–	1¼	1.255*	1.080	1.280
TCF125-147AL	–	1¼	1.255*	1.270	1.470
TCF150-115AL	–	1½	1.470	0.890	1.150
TCF150-140AL	–	1½	1.470	1.140	1.400
TCF150-165AL	–	1½	1.470*	1.390	1.650
TCF200-153AL	–	2	1.896	1.190	1.530
TCF200-186AL	–	2	1.896	1.520	1.860
TCF200-219AL	–	2	2.062*	1.850	2.190
TCF250-252AL	–	2½	2.466*	2.120	2.520
TCF300-278AL	–	3	2.780	2.380	2.780
TCF300-304AL	–	3	3.050	2.640	3.040
TCF300-330AL	–	3	3.068*	2.900	3.300

## Accessories



### Fitting selectors

Identifying the correct fitting is made easy with ABB fitting selectors. Whether for use with power, instrumentation or data transmission cables, simply align the selector with the cable brand, voltage and gauge being used and the appropriate Star Teck fitting catalogue numbers are identified in the selector window.

Two selectors are currently available through your local electrical distributor or ABB regional sales office:

- Star Teck (ST) Series and Star Teck XP (STX) series selector
- Star Teck Extreme (STE) series and Star Teck Extreme XP (STEX) series selector

**Cat. no.** Starteck REG (black)

For ST and STX series

**Cat. no.** Starteck EXT (red)

For STE and STEX series

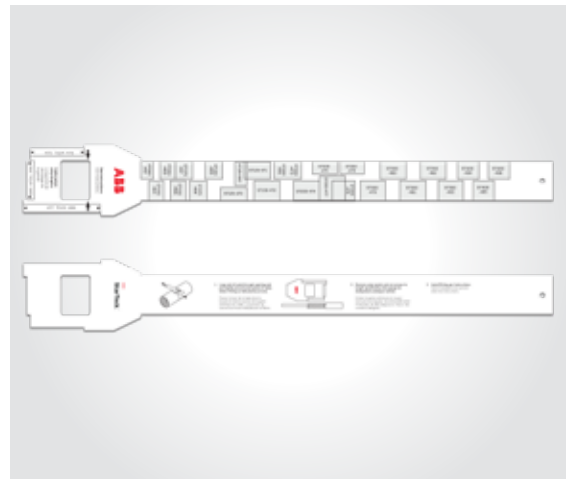

### Fitting scales

These wrap-around belt scales allow end-users to match cable to fitting on site, quickly and easily. The belts wrap around the circumference of the cable, clearly identifying the appropriate size(s) of fitting to use. The belt also incorporates a strip length gauge that indicates the correct length of armour to expose for proper grounding. The belt scales are available through your local electrical distributor or ABB regional sales office.

**Cat. no.** Starteck ruler

**Cat. no.** 2520 ruler

**Cat. no.** HLT ruler